

Light & More



flexx

Welcome!

Hi!

Light & More	8
Best of the Best	19
Acoustic	24
Design	68
Flexx Line	112
Professional	126
Movy	146

Are you ready?

**First,
a little
introduction
to Light...
and More.**

Light & More

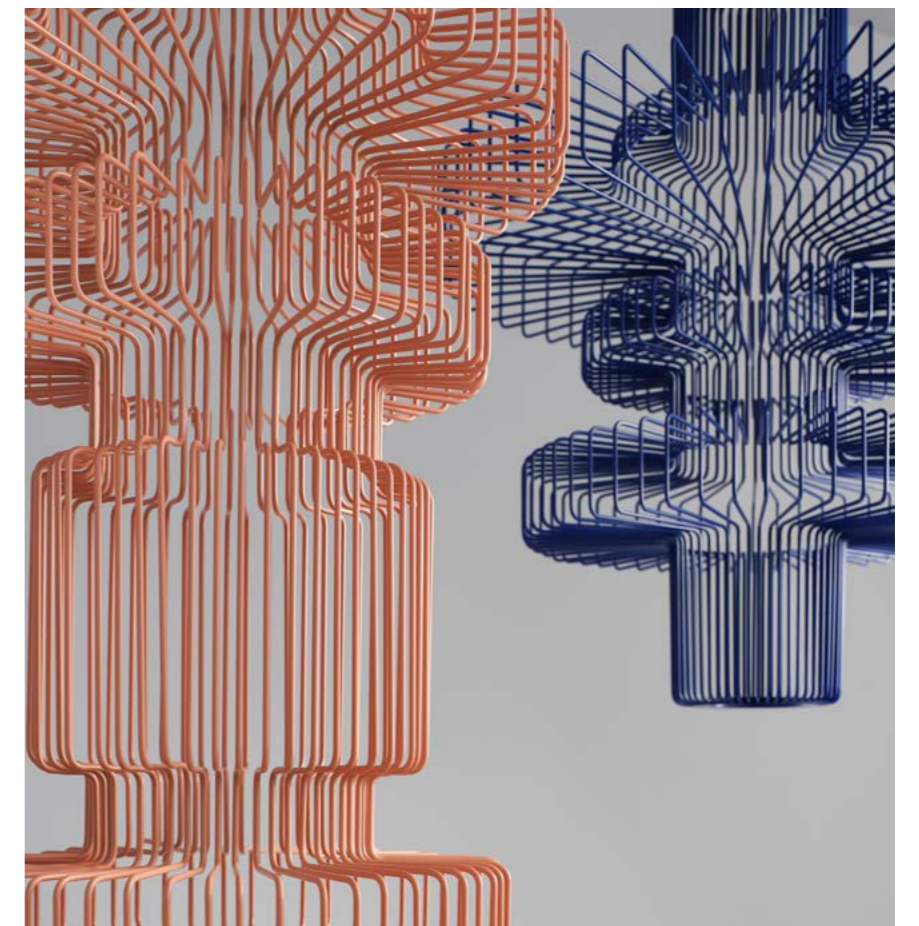
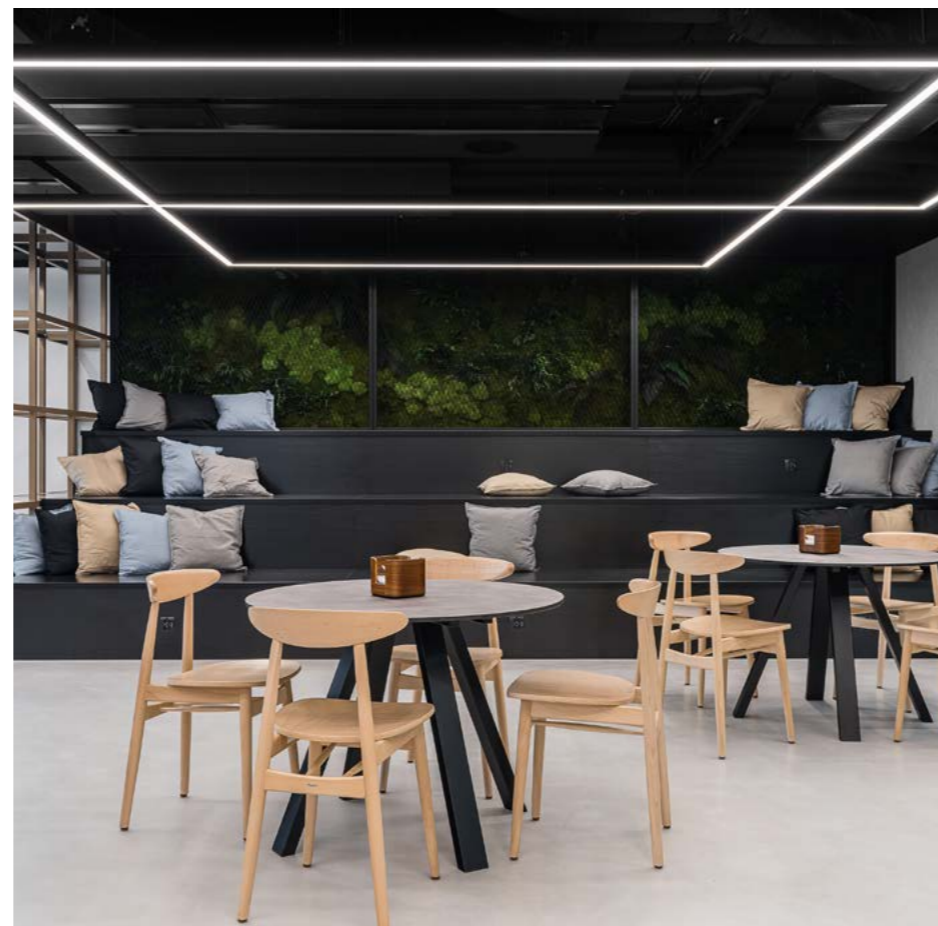
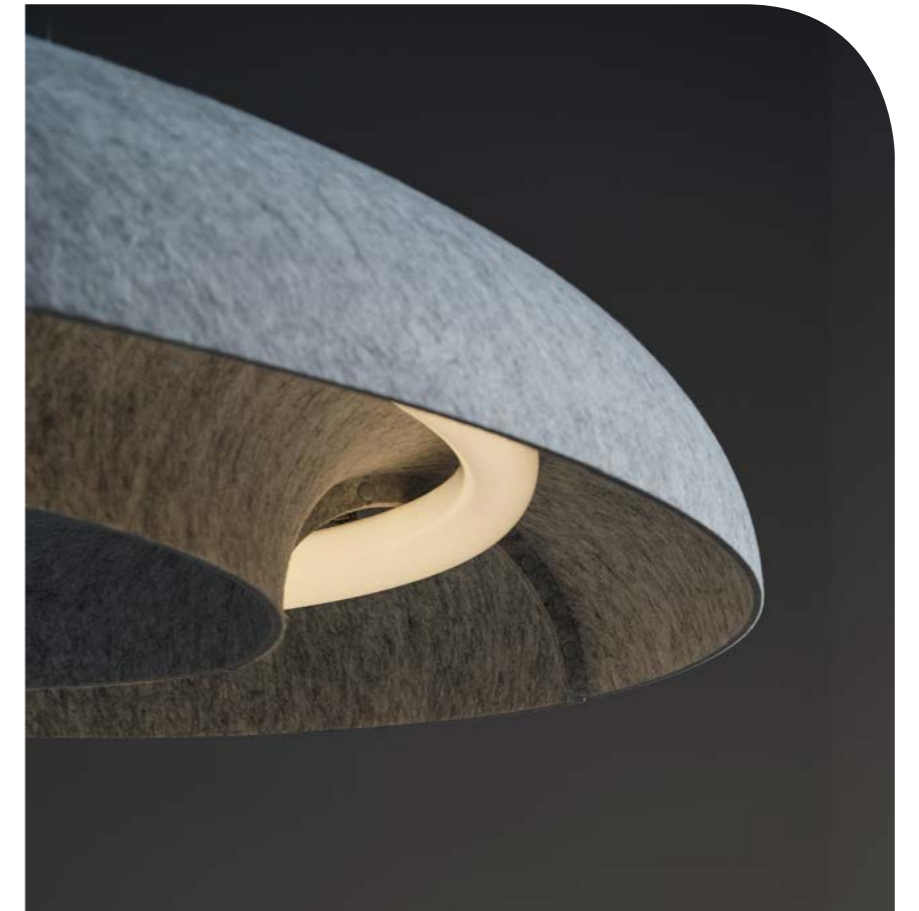

Acoustic comfort

The design of office spaces includes many aspects. That is why our luminaire designs are not limited to fulfilling only one function. One of the uses is to provide acoustic comfort for the user. Thanks to properly selected materials and fabrics in our luminaires, we achieve satisfying results in reducing noise levels. This is one of the many advantages of our luminaires, and there are many more!

DE

Die Gestaltung von Büroräumen deckt viele Aspekte ab. Daher sind wir in unseren Entwürfen nicht nur auf eine Funktion beschränkt. Eine der Anwendungen besteht darin, dem Benutzer akustischen Komfort zu bieten. Dank richtig ausgewählter Materialien und Stoffe in unseren Leuchten erzielen wir überzeugende Ergebnisse bei der Reduzierung des Lärmpegels. Dies ist einer der vielen Vorteile unserer Leuchten, und es gibt noch viele weitere!



Natural inspiration

We often cross impossible boundaries in our projects. We combine seemingly incompatible elements – to form a single whole. This is the case with vegetation. Placing it in our luminaires is what makes them something absolutely unbelievable. By creating a kind of ecosystem in the midst of light, we affect the internal peace of those using our lighting.

DE

In unseren Projekten überschreiten wir oft unmögliche Grenzen. Wir verbinden scheinbar inkompatible Elemente einheitlich zusammen. Dies ist in der Pflanzenwelt gerade der Fall. Es ist die Verwendung der Pflanzen in unseren Leuchten, die sie absolut unglaublich macht. Indem wir eine Art Ökosystem inmitten der Welt der Lichter schaffen, sorgen wir für inneren Frieden der Benutzer unserer Beleuchtung.



Rhythm of the day

Each of us has different preferences regarding the intensity and temperature of light in which we like to work. Moreover, this varies throughout the day. Therefore, most of our luminaires have control modules, allowing manual or automatic adjustment of these parameters to the user's personal preferences.

DE

Jeder von uns hat unterschiedliche Vorlieben hinsichtlich der Intensität und Temperatur des Lichts, bei dem wir gerne arbeiten. Darüber hinaus ist es den ganzen Tag über variabel. Daher verfügen unsere Leuchten meist über Steuermodule, mit denen diese Parameter manuell oder automatisch an die persönlichen Präferenzen der Benutzer angepasst werden können.



Size does matter

We are very flexible, and each of our projects is different and requires tailored solutions. We have a wide range of luminaires in various sizes, including XXL solutions for particularly large rooms.

DE
Wir sind sehr flexibel und jedes unserer Projekte ist anders und erfordert individuelle Lösungen. Wir haben ein breites Sortiment an Leuchten in verschiedenen Größen, bis hin zu XXL-Lösungen für besonders große Räume.

XXL luminaires



Acoustic Cone 31



Acoustic Island 43



Acoustic Roller 55

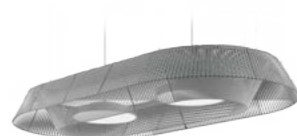

Ribbon 99



Product & design strategy



EN
Duo Katarzyna Borkowska and Tomasz Pydo – KABO & PYDO interdisciplinary design studio.
They always create with perfect attention to the esthetic, functional and ergonomic features of their products, which then become market hits – inspiring recognition of satisfied customers.

DE
Das Duo Katarzyna Borkowska und Tomasz Pydo – KABO & PYDO interdisziplinäres Designstudio.
Sie kreieren immer mit perfekter Aufmerksamkeit auf die ästhetischen, funktionalen und ergonomischen Eigenschaften der entworfenen Produkte, die dann zu Markterfolgen werden – und die Anerkennung zufriedener Kunden wecken.

Best of the Best

EN

We are continuously investing in research and development. We focus on patterns, and thanks to the partnership with KABO & PYDO, a whole collection of lamps with unique design was created. We won three international Red Dot Design Awards (also known as "Design Oscars") including the "Best of the Best" award for the world's best acoustic luminaire!

The Wire Medusa luminaire, besides the Red Dot Awards, has also been recognized with the Must Have prize. The other series of lamps are also enjoying recognition by the jurors of international competitions, among others, the German Design Award, where the Acoustic Cone lamp has been nominated.

DE

Wir investieren ständig in Forschung und Entwicklung. Wir setzen auf Design und dank der Zusammenarbeit mit KABO & PYDO ist eine ganze Leuchtenkollektion von einem einzigartigen Design entstanden. Wir haben drei internationale Preise Red Dot Design Award (auch bekannt als „Design Oscars“) gewonnen, darunter den „Best of The Best“-Preis für den besten akustischen Leuchtenin der Welt!

Neben dem Red Dot Award wurde die Leuchte Wire Medusa mit dem Preis Must Have Award ausgezeichnet. Auch die anderen Lampenserien werden von Juroren internationaler Wettbewerbe geschätzt, darunter German Design Award, für den die Leuchte Acoustic Cone nominiert wurde.



reddot winner 2021
best of the best

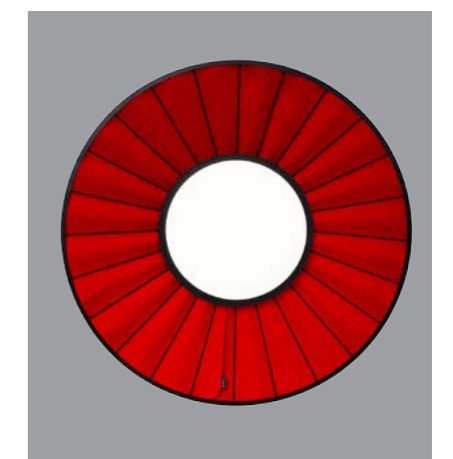

reddot winner 2021



reddot winner 2021



We are
#Best of the Best!

**Acoustic
lighting.**

**More *silence*
in the office!**

Acoustic lighting



Acoustic



Acoustic Team 29



Acoustic Cone 31



Acoustic Gap Round Slim 45



Acoustic Gap Round 47



Acoustic Shade 33



Acoustic Quadro 35

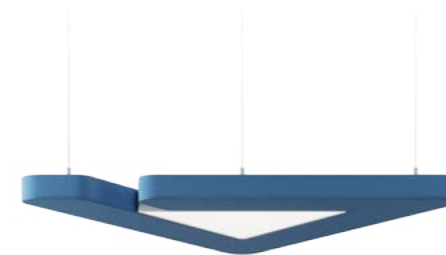

Acoustic Gap Triangle 49



Acoustic Gap Island 51



Acoustic Gaya 53



Acoustic Roller 55



Acoustic Ring 37



Acoustic Square 39



Acoustic Hillock 57



Acoustic Blade 59



Acoustic Round 41



Acoustic Island 43

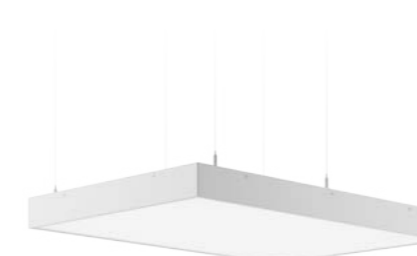

Acoustic Panel 61



Acoustic Sphere 63



reddot winner 2021
best of the best



Acoustic Team

EN

A modular lamp made of three different components that can be combined in different ways. Thanks to the domed shade and the pressed fabric, the lamp absorbs some of the ambient sound. These features make it perfect for office environments, such as open-plan offices. Thanks to its excellent design, it creates a warm atmosphere in any interior. Recycled plastic bottles have been used to make the shade. The luminaire is available in two lighting options – for ambient lighting and for work. The color of the shade can be customized.

The lamp was awarded the Red Dot Award: Best of the Best 2021, designed by Kabo & Pydo – Design Studio.

DE

Modullampe mit drei verschiedenen Elementen, die beliebig kombiniert werden können. Die Kuppelform des Lampenschirms und das gepresste Material sorgen dafür, dass die Lampe einen Teil der Umgebungsgläusche absorbiert. Deshalb eignet sich das Modell perfekt für Büroarbeitsplätze, wie etwa in Open Space-Büros. Dank des ausgezeichneten Designs bringt sie eine warme Stimmung in den Raum. Bei der Herstellung des Lampenschirms wurden recycelte Plastikflaschen verarbeitet. Die Lampe ist in zwei Beleuchtungsvarianten erhältlich – als Deko-Leuchte und zur Arbeit. Möglichkeit zur Personalisierung der Farbe des Lampenschirms.

Die Lampe wurde mit der Auszeichnung Red Dot: Best of the Best 2021 ausgezeichnet, Entw. Kabo & Pydo – Design Studio.

color temperature	3000K
	4000K
electrical control	DIMM DALI
	ON/OFF
housing color	white
	black
mounting type	pendant
IP	IP20
CRI	>80
UGR	<19

AVAILABLE COLORS



*Original product colors may vary from those illustrated.



Acoustic Cone

EN

Thanks to the bold combination of an industrial shade and acoustic fabric, an unusual model of office luminaire was created. The top quality design, noise attenuation and, above all, excellent technical parameters – all these are the features of a luminaire ideal for work. The product offers the possibility of personalizing the color of the fabric based on the BWF Feltec's color-PRISM range.

Acoustic Cone was nominated for the German Design Award 2021 in the category Excellent Product Design.

DE

Dank der kühnen Kombination eines industriellen Lampenschirms mit einem akustischen Stoff wurde ein ungewöhnliches Modell einer Büroleuchte geschaffen. Design höchster Qualität, Geräuscherdrückung und vor allem hervorragende technische Parameter – all dies sind die Merkmale der Leuchte, die sich ideal für die Arbeit eignet. Die Farbe des Stoffes kann, basierend auf der Farbpalette der colorPRISM-Stoffe von BWF Feltec, personalisiert werden.

Acoustic Cone wurde für den German Design Award 2021 in der Kategorie Excellent Product Design nominiert.

system power	30W Acoustic Cone 1070x150
	48W Acoustic Cone 1430x200
light distribution - up	100°
light distribution - down	95°
color temperature	3000K
	4000K
	6000K
	TUNABLE WHITE
electrical control	1-10V
	DIMM DALI
	1-10V tunable white motion + daylight sensor
	ON/OFF
housing color	white
	black
fabric color	Design Felt by M&K Filze color palette
	colorPRISM BWF Feltec palette
mounting type	pendant
IP	IP20
CRI	>80
UGR	<18

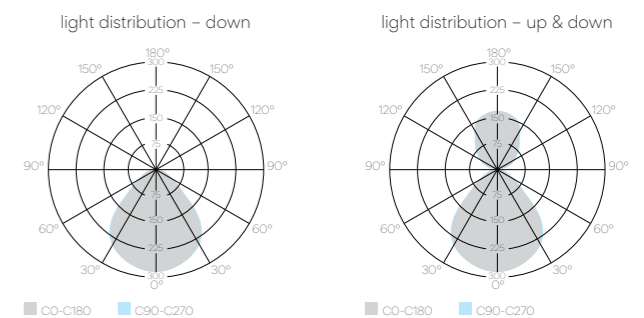
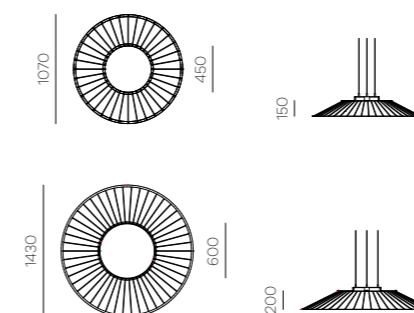



Acoustic Shade

EN

Acoustic lamp with an extraordinary shape. The modern wire processing techniques allowed us to achieve the unique industrial design of the lampshade. Woven with acoustic fabric, its new features include a warmer look and sound absorption. The color of the fabric is fully customisable, so you can select the one that complements your interior design. With the top-quality lighting components, the luminaire is an excellent choice for the office, especially for open-plan spaces.

DE

Akustiklampe mit außergewöhnlicher Form. Dank moderner Drahtverarbeitungstechniken konnte eine einzigartige industrielle Form des Lampenschirms gestaltet werden. Der geflochtene Akustikstoff sorgt nicht nur für einen wärmeren Look, sondern auch für die Schallabsorption. Die Farbe des Stoffes ist vollständig personalisiert. Einfach entsprechend Ihrer Raumgestaltungspläne auswählen. Die Leuchte eignet sich dank der hochwertigen Beleuchtungskomponenten ideal für Büros, insbesondere für Open Space-Flächen.

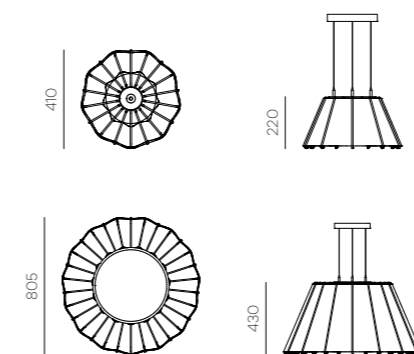

	Acoustic Shade 410 x 220	Acoustic Shade 805 x 430
system power	GU10	30W
light distribution - up	-	100°
light distribution - down	10° 36° 60° 120°	95°
color temperature	2700K	
	3000K	3000K
	4000K	4000K
	5000K	6000K
	TUNABLE WHITE	TUNABLE WHITE
electrical control	1-10V	1-10V
	DIMM DALI	DIMM DALI
	ON/OFF	ON/OFF
		1-10V tunable white motion + daylight sensor
housing color	white	white
	black	black
fabric color	Design Felt by M&K Filze color palette	Design Felt by M&K Filze color palette
	colorPRISM BWF Feltec palette	colorPRISM BWF Feltec palette
mounting type	pendant	pendant
IP	IP20	IP20
CRI	>80	>80
UGR	<18	<18

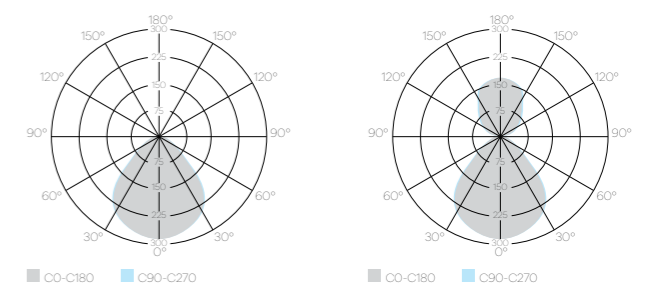

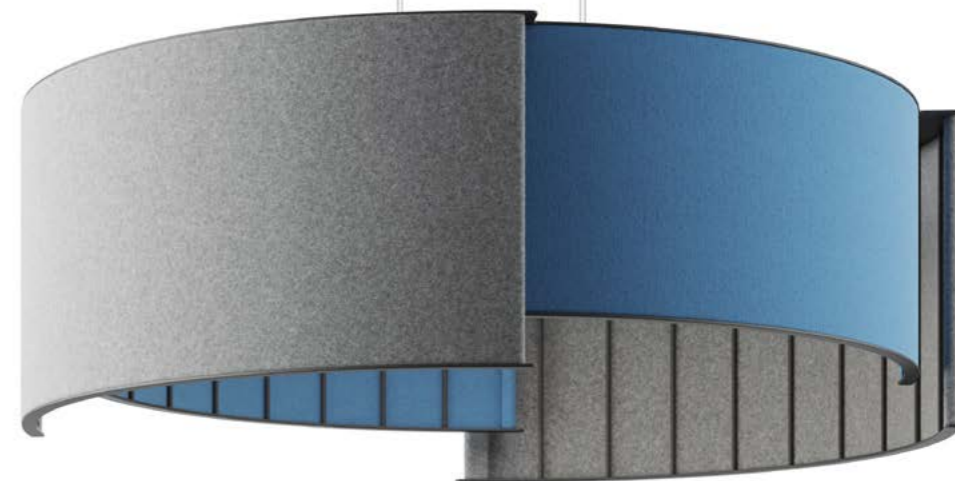

Acoustic Quadro

EN

A lamp consisting of independent four acoustic quadrants with an industrial-style frame. Its color and frame are fully customisable – you can choose from our color palette to match your design. Made of soft materials, it absorbs sounds that reach its surface. With its top-quality lighting components, it is perfect for offices, especially the open-plan type.

DE

Eine Lampe aus vier unabhängigen Akustikvierteln mit industriellem Rahmen. Unbegrenzte Möglichkeiten zur Personalisierung der Farbe des Stoffs und Rahmen – je nach Projekt kann aus unserer Farbpalette gewählt werden. Dank der verwendeten weichen Materialien absorbiert das Modell die Geräusche, die den Lampenschirm erreichen. Aufgrund der hochwertigen Beleuchtungskomponenten eignet sich die Lampe ideal für Büroräume, insbesondere für Open Space-Flächen.

system power	30W Acoustic Quadro 710×630
	48W Acoustic Quadro 910×830
light distribution - up	100°
light distribution - down	95°
color temperature	3000K
	4000K
	6000K
	TUNABLE WHITE
electrical control	1-10V
	DIMM DALI
	1-10V tunable white motion + daylight sensor
	ON/OFF
housing color	white
	black
fabric color	Design Felt by M&K Filze color palette
	colorPRISM BWF Feltec palette
mounting type	pendant
IP	IP20
CRI	>80
UGR	<18

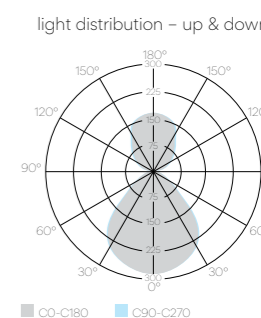
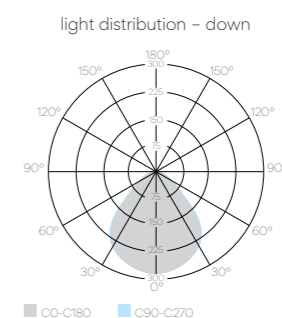
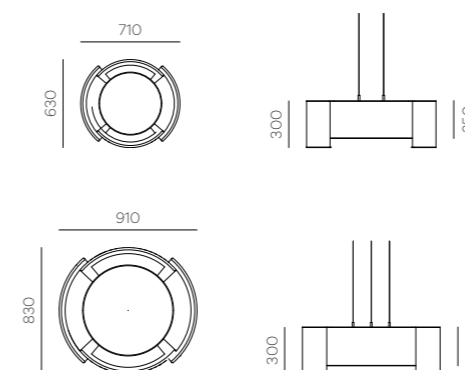



Acoustic Ring

EN

Acoustic luminaire shaped like a large circle. The lamp consists of a band-shaped light component around a soft panel. Due to its size, the lamp will work well in office spaces such as conference rooms. It will perfectly illuminate such spaces, giving them a touch of elegance and increasing the comfort of work.

DE

Große kreisförmige Akustikleuchte. Die Lampe besteht aus einem bandförmigen Leuchtabschnitt rund um ein weiches Paneel. Aufgrund ihrer Größe eignet sich die Lampe perfekt für Büroräume und Konferenzsäle. Das Modell beleuchtet derartige Räume perfekt, verleiht ihnen Eleganz und erhöht dabei den Arbeitskomfort.

system power	60W
light distribution - down	symetric
color temperature	3000K
	4000K
electrical control	1-10V
	DIMM DALI
	ON/OFF
housing color	white
	black
fabric color	Synergy by Camira color palette
mounting type	pendant
IP	IP20
CRI	>80
UGR	<18

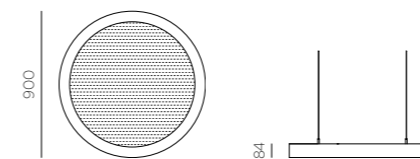



Acoustic Square

EN

This acoustic lamp has a geometric, slightly truncated shape. Both the inner light component and the surrounding acoustic panel are shaped like a square. The large surface area of the panel allows effective absorption of ambient sounds. The color of the panel is customizable. These features make the lamp a perfect choice for office workplaces, especially open-plan offices.

DE

Akustiklampe in geometrischer, leicht geschnittener Form. Sowohl das Leuchtelement innen als auch das Akustikpaneel haben eine quadratische Form. Die große Oberfläche des Paneels sorgt für eine effektive Absorption der Umgebungsgläusche. Möglichkeit zur Personalisierung der Paneelfarbe. Dank dieser Eigenschaften ist die Lampe ideal für Büroarbeitsplätze geeignet, insbesondere für Open Space-Flächen.

system power	30W
	36W
	40W
light distribution - down	120°
color temperature	3000K
	4000K
electrical control	1-10V
	DIMM DALI
	ON/OFF
housing color	white
fabric color	Synergy by Camira color palette
mounting type	pendant
IP	IP40
CRI	>80
UGR	<19

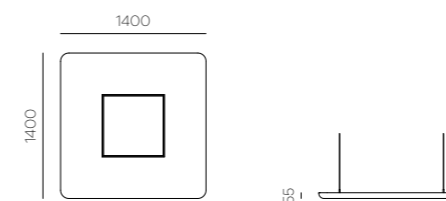

We can make it in other sizes!

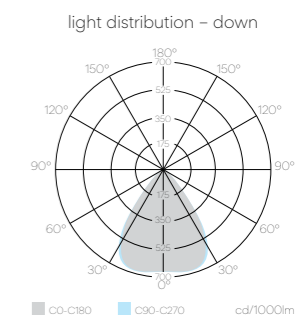



Acoustic Round

EN

Round lamp with upholstered acoustic panel. Equipped with a round light panel with excellent light characteristics, with a choice of light color and up/down lightning direction. The color of the lamp panel can be fully adjusted. Thanks to the materials used it absorbs a large proportion of the sounds that reach it. Combined with high-quality lighting components, it is ideal for office spaces, especially open plan offices.

DE

Runde Lampe mit gepolstertem Akustikpaneel. Ausgestattet mit einem runden Leuchtpaneel mit hervorragenden Beleuchtungsparametern und der Möglichkeit, die Lichtfarbe und die Beleuchtungsrichtung nach oben/unten zu wählen. Die Farbe des Lampenpaneels kann vollständig angepasst werden. Dank den verwendeten Materialien absorbiert die Lampe einen Großteil des Schalls, der sie erreicht. In Kombination mit hochwertigen Lichtkomponenten ist sie ideal für Büroräume, insbesondere Großraumbüros.

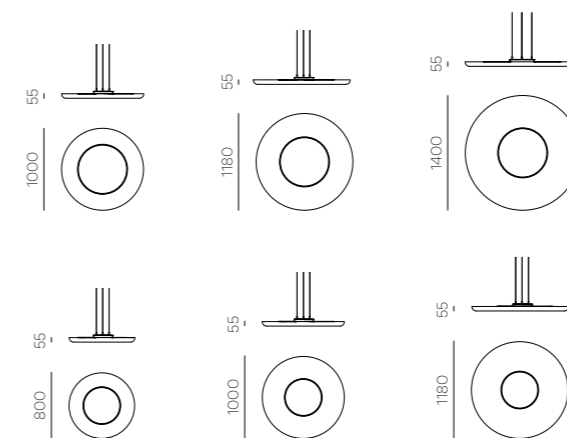

We can make it in other sizes!

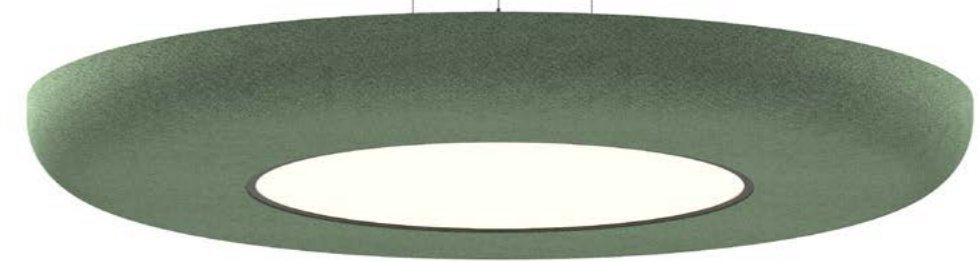

system power	30W
	48W
light distribution - up	100°
light distribution - down	95°
color temperature	3000K
	4000K
	6000K
	TUNABLE WHITE
electrical control	1-10V
	DIMM DALI
	1-10V tunable white motion + daylight sensor
	ON/OFF
housing color	white
	black
fabric color	Synergy by Camira color palette
mounting type	pendant
IP	IP20
CRI	>80
UGR	<18

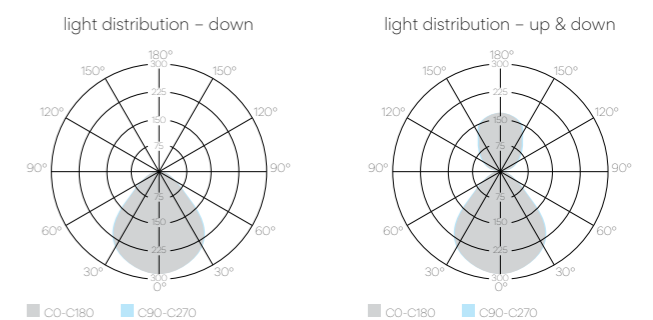



Acoustic Island

EN

Acoustic luminaire in XXL size. With its large surface panel, it is suitable for open-plan offices or conference rooms. It absorbs a significant amount of the surrounding sound. The full panel creates an eye-catching feature in the space. Panel sizes and colors are fully customisable.

DE

Akustiklampe im XXL-Format. Dank des großflächigen Paneels eignet sich das Modell perfekt für Open Space-Büros oder Konferenzräume. Die Lampe absorbiert einen großen Teil der Geräusche aus der unmittelbaren Umgebung. Vollständiges Paneel – interessantes Element im Raum. Passen Sie Größe und Farbe des Paneels an die Anforderungen Ihres Projekts an.

system power	2×16W
light distribution - down	18°
color temperature	3000K 4000K TUNABLE WHITE
electrical control	1-10V DIMM DALI 1-10V tunable white motion + daylight sensor ON/OFF
housing color	white black
fabric color	Synergy by Camira color palette
mounting type	pendant
IP	IP20
CRI	>80
UGR	<18

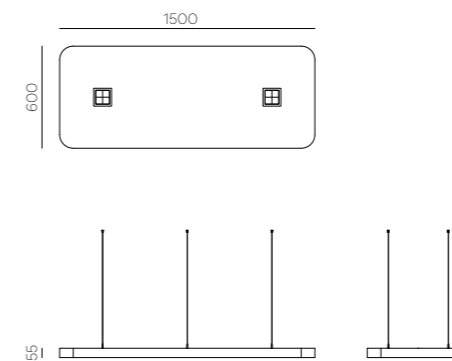

We can make it in other sizes!

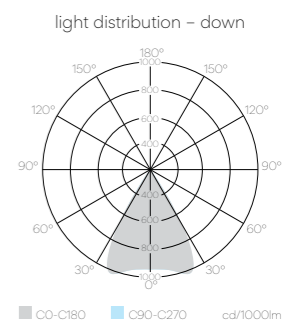



Acoustic Gap Round Slim

EN

Round lamp with an acoustic panel. The distinguishing embossing and cut-out give it a unique designer look. The panel color is fully customisable. The materials absorb the surrounding sounds. This, with its high-quality lighting components, makes it perfect for offices, particularly in open-plan spaces.

DE

Runde Lampe mit Akustikpaneel. Die charakteristische Prägung und die Kerbe sorgen für einen einzigartigen Designer-Look. Unbegrenzte Möglichkeiten zur Personalisierung der Paneelfarbe. Dank der verwendeten Materialien absorbiert die Lampe einen Teil der Geräusche, die sie erreichen. Aufgrund der hochwertigen Beleuchtungskomponenten eignet sich die Lampe ideal für Büroräume, insbesondere für Open Space-Flächen.

system power	30W Acoustic Gap Round Slim 810×35
	30W Acoustic Gap Round Slim 1080×35
light distribution - up	100°
light distribution - down	95°
color temperature	3000K
	4000K
	6000K
	TUNABLE WHITE
electrical control	1-10V
	DIMM DALI
	1-10V tunable white motion + daylight sensor
	ON/OFF
housing color	white
	black
fabric color	
mounting type	pendant
IP	IP20
CRI	>80
UGR	<18

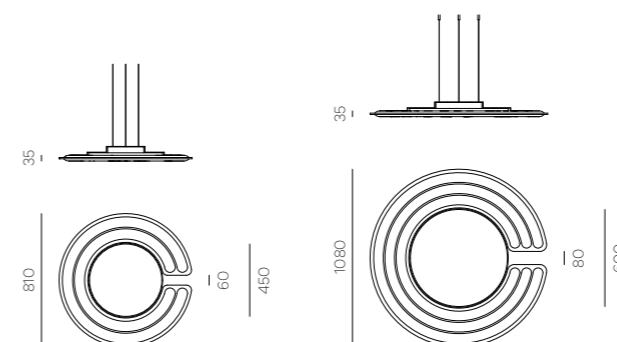

We can make it in other sizes!

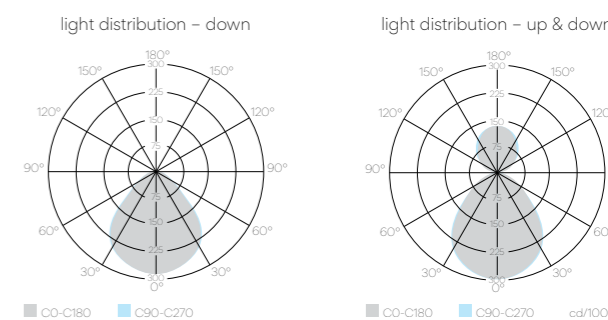

flexx



Acoustic Gap Round

EN

Round lamp with an upholstered acoustic panel. The distinctive cut-out gives it a unique designer look. The panel color is fully customisable. The materials absorb a considerable part of the surrounding sounds. This, with its high-quality lighting components, makes it perfect for offices, particularly in open-plan spaces.

DE

Runde Lampe mit gepolstertem Akustikpaneel. Die charakteristische Kerbe sorgt für einen einzigartigen Designer-Look. Unbegrenzte Möglichkeiten zur Personalisierung der Paneelfarbe. Dank der verwendeten Materialien absorbiert die Lampe einen großen Teil der Geräusche, die sie erreichen. Aufgrund der hochwertigen Beleuchtungskomponenten eignet sich die Lampe ideal für Büroräume, insbesondere für Open Space-Flächen.

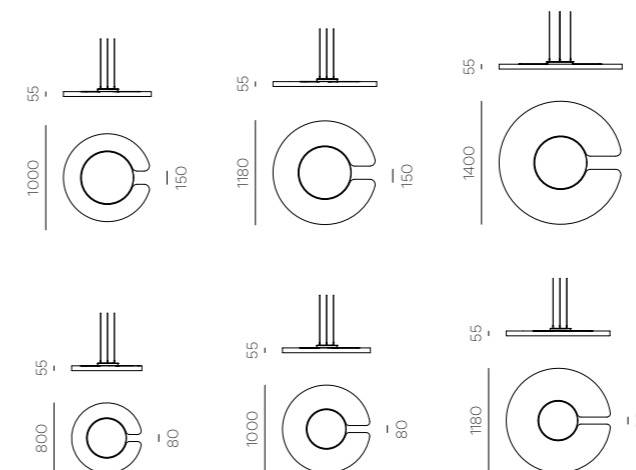

We can make it in other sizes!



system power	30W Acoustic Gap Round 930×55
	48W Acoustic Gap Round 1180×55
light distribution - up	100°
light distribution - down	95°
color temperature	3000K
	4000K
	6000K
	TUNABLE WHITE
electrical control	1-10V
	DIMM DALI
	1-10V tunable white motion + daylight sensor
	ON/OFF
housing color	white
	black
fabric color	Synergy by Camira color palette
mounting type	pendant
IP	IP20
CRI	>80
UGR	<18

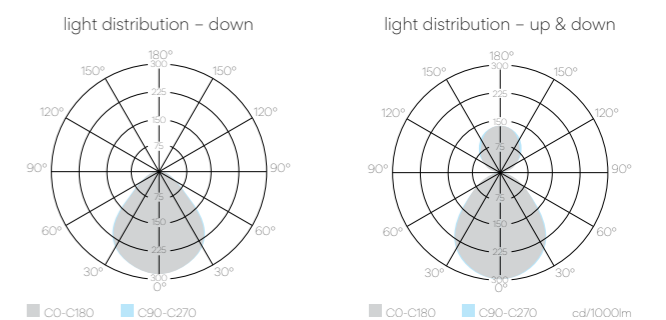

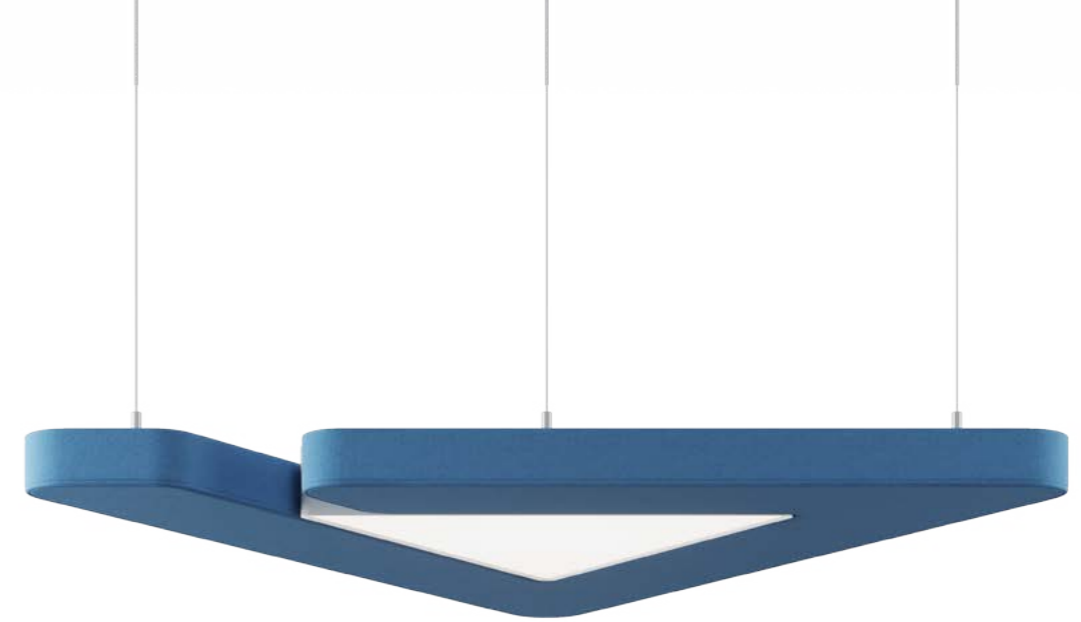

Acoustic Gap Triangle

EN

Triangular lamp with an upholstered acoustic panel. The distinctive cut-out gives it a unique designer look. The panel color is fully customisable. The materials absorb a considerable part of the surrounding sounds. This, with its high-quality lighting components, makes it perfect for offices, particularly in open-plan spaces.

DE

Dreieckige Lampe mit gepolstertem Akustikpaneel. Die charakteristische Kerbe sorgt für einen einzigartigen Designer-Look. Unbegrenzte Möglichkeiten zur Personalisierung der Paneelfarbe. Dank der verwendeten Materialien absorbiert die Lampe einen großen Teil der Geräusche, die sie erreichen. Aufgrund der hochwertigen Beleuchtungskomponenten eignet sich die Lampe ideal für Büroräume, insbesondere für Open Space-Flächen.

system power	30W
light distribution - down	120°
color temperature	3000K 4000K
electrical control	1-10V DIMM DALI ON/OFF
housing color	white black
fabric color	Synergy by Camira color palette
mounting type	pendant
IP	IP20
CRI	>80
UGR	<19

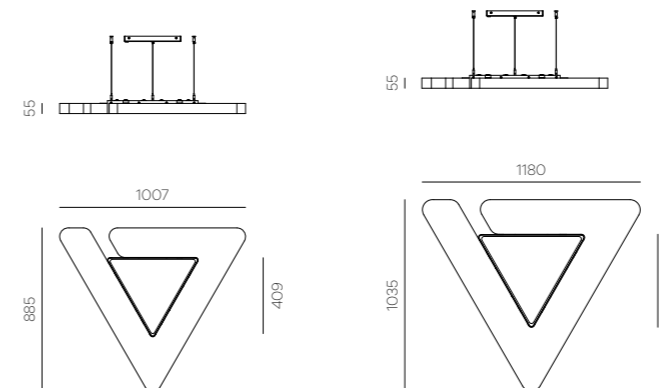

We can make it in other sizes!



Acoustic Gap Island

EN

Acoustic luminaire in XXL size. With its large surface panel, it is suitable for open-plan offices or conference rooms. It absorbs a significant amount of the surrounding sound. The panel has a characteristic cut-out, which is an eye-catching detail that adds lightness to the lamp. Panel sizes and colors are fully customizable.

DE

Akustiklampe im XXL-Format. Dank des großflächigen Paneels eignet sich das Modell perfekt für Open Space-Büros oder Konferenzräume. Die Lampe absorbiert einen großen Teil der Geräusche aus der unmittelbaren Umgebung. Das Paneel hat eine charakteristische Kerbe – ein auffälliges Detail, das der Lampe Leichtigkeit verleiht. Passen Sie Größe und Farbe des Paneels an die Anforderungen Ihres Projekts an.

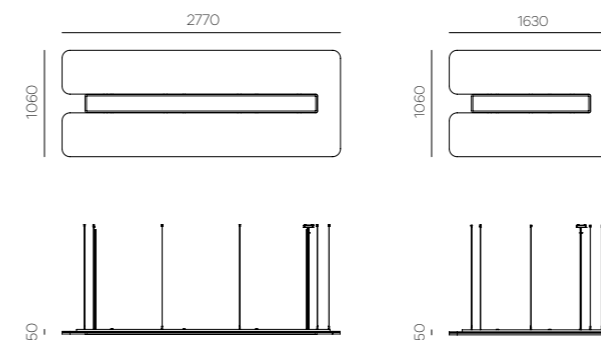

system power	52W Acoustic Gap Island 1630×1060×55
	88W Acoustic Gap Island 2770×1060×55
color temperature	3000K
	4000K
	6000K
	TUNABLE WHITE
electrical control	1-10V
	DIMM DALI
	1-10V tunable white motion + daylight sensor
	ON/OFF
housing color	white
	black
fabric color	Synergy by Camira color palette
mounting type	pendant
IP	IP20
CRI	>80
UGR	<19



Acoustic Gaya

EN

A distinctive lamp inspired by biophilic design. The lamp consists of two acoustic panels, a light component and an inner shield shaped like a plant pot to plant anything. The luminaire not only perfectly illuminates the workplace but also enhances the visual value of the interior and gives it a classy character. The color of all the components of the lamp is customisable.

The lamp was designed in collaboration with Trzop Architekci, arch. Małgorzata Szlązek.

DE

Charakteristische Lampe im Biophilic Design-Look. Die Lampe besteht aus zwei Akustikpaneels, einem Leuchtelement und einem Innenschirm in Form eines Blumentopfes für Pflanzen. Die Lampe beleuchtet nicht nur den Arbeitsplatz perfekt, sondern erhöht auch den visuellen Wert des Raums und verleiht ihm ein elegantes Flair. Möglichkeit zur Personalisierung der Farbe aller Komponenten der Lampe.

Die Lampe wurde in Zusammenarbeit mit Trzop Architekci, arch. Małgorzata Szlązek.

system power	35W
light distribution - up	60°
color temperature	3000K 4000K
electrical control	1-10V DIMM DALI ON/OFF
housing color	white black copper
fabric color	Synergy by Camira color palette
mounting type	pendant
IP	IP20
CRI	>80
UGR	<18

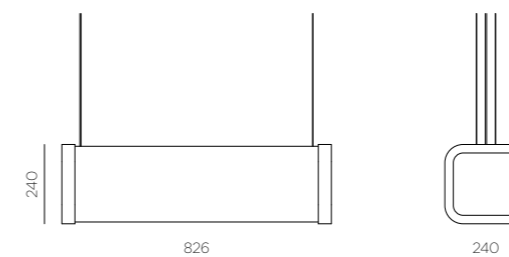



Acoustic Roller

EN

Acoustic Roller luminaire with an upholstered high-density acoustic lampshade. The materials used, such as a sponge, absorb a significant proportion of the sounds that reach it. Thanks to this and the high-quality lighting system used, it is an excellent choice for office workplaces, particularly in open-plan offices with considerable noise levels.

DE

Acoustic Roller ist eine Akustiklampe mit besonders dichtem, gepolstertem Lampenschirm. Dank der verwendeten Materialien (u.a. Schwamm) absorbiert das Modell einen großen Teil der Umgebungsgeräusche. Dadurch und dank des verwendeten hochwertigen Beleuchtungssystems ist die Lampe ideal für Büroarbeitsplätze geeignet, insbesondere für Open Space-Flächen, in denen der Geräuschpegel enorm ist.

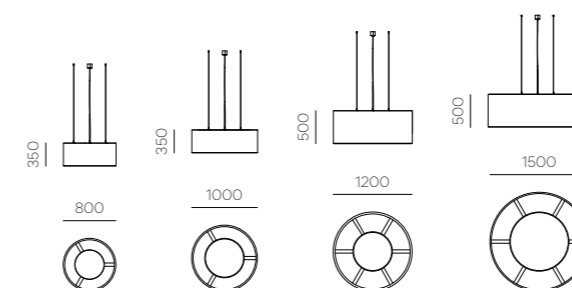

system power	30W Acoustic Roller 800×350
	48W Acoustic Roller 1000×350 / 1200×500
	80W Acoustic Roller 1500×500
light distribution - up	100°
light distribution - down	95°
color temperature	3000K
	4000K
	6000K
	TUNABLE WHITE
electrical control	1-10V
	DIMM DALI
	1-10V tunable white motion + daylight sensor
	ON/OFF
housing color	white
	black
fabric color	Synergy by Camira color palette
mounting type	pendant
IP	IP20
CRI	>80
UGR	<18

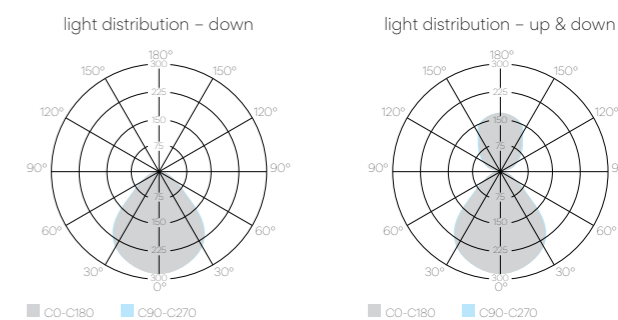



Acoustic Hillock

EN

Lamp with an acoustic lampshade. The characteristically geometrically curved lampshade allows for absorbing a considerable amount of incoming sounds. Its components are repetitive and modular, thanks to which we can obtain three different forms of the lamp. Depending on the size of the lampshade, the light source becomes a luminous profile or a plafond. With its top-quality components, the lamp is a perfect fit for open-plan offices.

DE

Lampe mit akustischem Lampenschirm. Die charakteristische, geometrisch gekrümmte Kuppel ist in der Lage, einen großen Teil der Geräusche zu absorbieren, die sie erreichen. Die Elemente des Lampenschirms sind wiederholbar und modular, so dass die Lampe in drei verschiedenen Formen konfiguriert werden kann. Je nach Größe des Lampenschirms wird die Lichtquelle als Lichtprofil oder Plafond geliefert. Aufgrund der hochwertigen Beleuchtungskomponenten eignet sich die Lampe ideal für Büroräume, insbesondere für Open Space-Flächen.

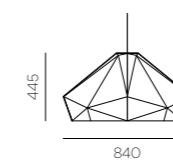
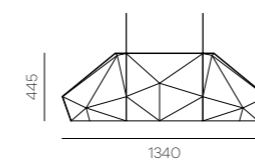
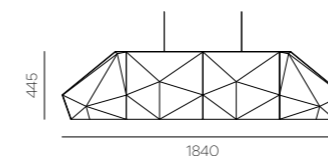

system power	1x12W Acoustic Hillock 840x445
	2x12W Acoustic Hillock 1340x445
	3x12W Acoustic Hillock 1840x445
light distribution - down	18°
color temperature	2700K
	3000K
	4000K
electrical control	1-10V
	DIMM DALI
	ON/OFF
shade color	PET color palette
mounting type	pendant
IP	IP20
CRI	>80
UGR	<18

AVAILABLE COLORS



* Original product colors may vary from those illustrated.

light distribution - down

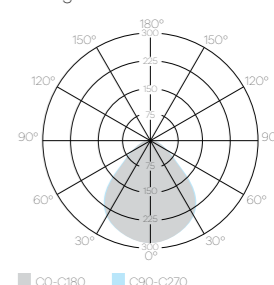



Acoustic Blade

EN

Acoustic Blade is an extraordinary acoustic luminaire. By using a PET panel with a large surface area, we have created a lamp that absorbs and isolates a significant proportion of ambient sounds. Due to its form, it can also serve as a partial barrier in open-plan offices. The lamp is equipped with high-quality light sources, making it a perfect fit for workplaces.

DE

Acoustic Blade ist eine Akustiklampe der besonderen Art. Dank des großflächigen PET-Moduls absorbiert und isoliert diese Lampe einen großen Teil der Umgebungsgeräusche. Aufgrund der Form kann das Modell auch als eine Art Teiltrennwand in Open Space-Büroräumen eingesetzt werden. Die Lampe ist mit hochwertigen Lichtquellen ausgestattet und eignet sich daher ideal für den Arbeitsplatz.

system power	23W
light distribution - down	65°
color temperature	3000K 4000K TUNABLE WHITE
electrical control	1-10V DIMM DALI 1-10V tunable white motion + daylight sensor ON/OFF
housing color	white black
shade color	silentec® by BWF Group Nitona® Flexx PET
mounting type	pendant
IP	IP20
CRI	>80

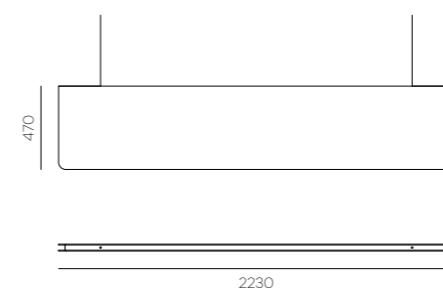

We can make it in other sizes!

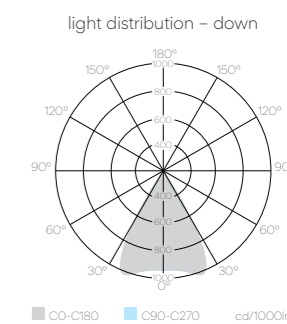



Acoustic Panel

EN

Luminaire is designed using a lightweight acoustic composite. With its simple form and large surface area, the lamp absorbs most of the sounds reaching its surface. The composite in its honeycomb pattern and structure adds depth to the simple geometric design of the luminaire. The composite also provides excellent light diffusion, making the lamp perfect for office workspaces. The lamp has a modular form and allows any combination and duplication of the shape of a single component.

DE

Entwickelt auf Basis eines leichten akustischen Verbundwerkstoffs. Dank der schlichten Form und großen Oberfläche absorbiert die Lampe die meisten Geräusche in der unmittelbaren Umgebung. Der Verbundstoff mit Wabenmuster und -struktur verleiht der einfachen geometrischen Struktur besondere Tiefe. Der Verbundstoff sorgt für die perfekte Streuung des Lichts und macht die Lampe zur idealen Wahl für Büroarbeitsplätze. Die Lampe hat eine modulare Form – beliebige Kombinationsmöglichkeiten und Vervielfältigung der Form eines einzelnen Elements.

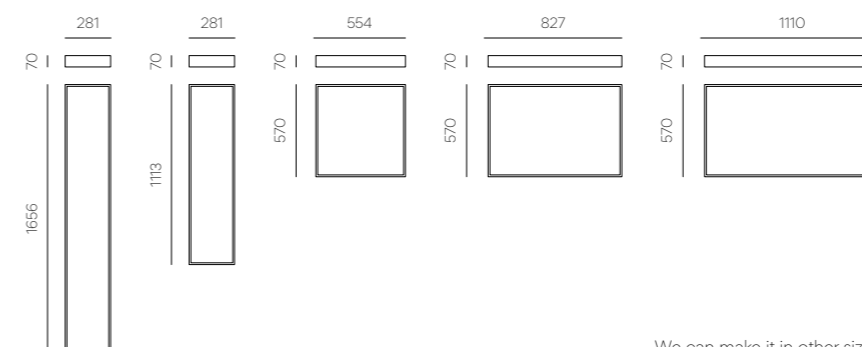

We can make it in other sizes!

system power	80W
color temperature	3000K 4000K
electrical control	1-10V DIMM DALI ON/OFF
housing color	white
mounting type	pendant
IP	IP40
CRI	>80
UGR	<19



Acoustic Sphere

EN

Round lamp with upholstered acoustic panel. The distinctive hanging sphere in the center of the panel gives it a unique, designer look. The color of the lamp panel can be fully customized. Thanks to the materials used, it absorbs a large proportion of the sound that reaches it. Paired with high-quality light components, it is ideal for office spaces, especially for open-plan offices.

DE

Runde Lampe mit gepolstertem Akustikpaneel. Die charakteristische hängende Kugel in der Mitte des Paneels verleiht ihr einen einzigartigen Designerlook. Bei dieser Lampe kann die Farbe des Paneels beliebig personalisiert werden. Dank der verwendeten Materialien absorbiert das Modell einen erheblichen Teil der Umgebungsgeräusche. Angesichts der gleichzeitigen Verwendung hochwertiger Beleuchtungskomponenten eignet sich die Lampe ideal für Büroräume, und insbesondere für Open Space-Flächen.

system power	25W
color temperature	3000K 4000K
electrical control	1-10V DIMM DALI ON/OFF
housing color	white
fabric color	Synergy by Camira color palette
mounting type	pendant
IP	IP40
CRI	>80
UGR	<19



We can make it in other sizes!

**For us,
#light and
#acoustics
are user's
well-being.**

More
#award
winning
and
#designer
luminaires.

Design

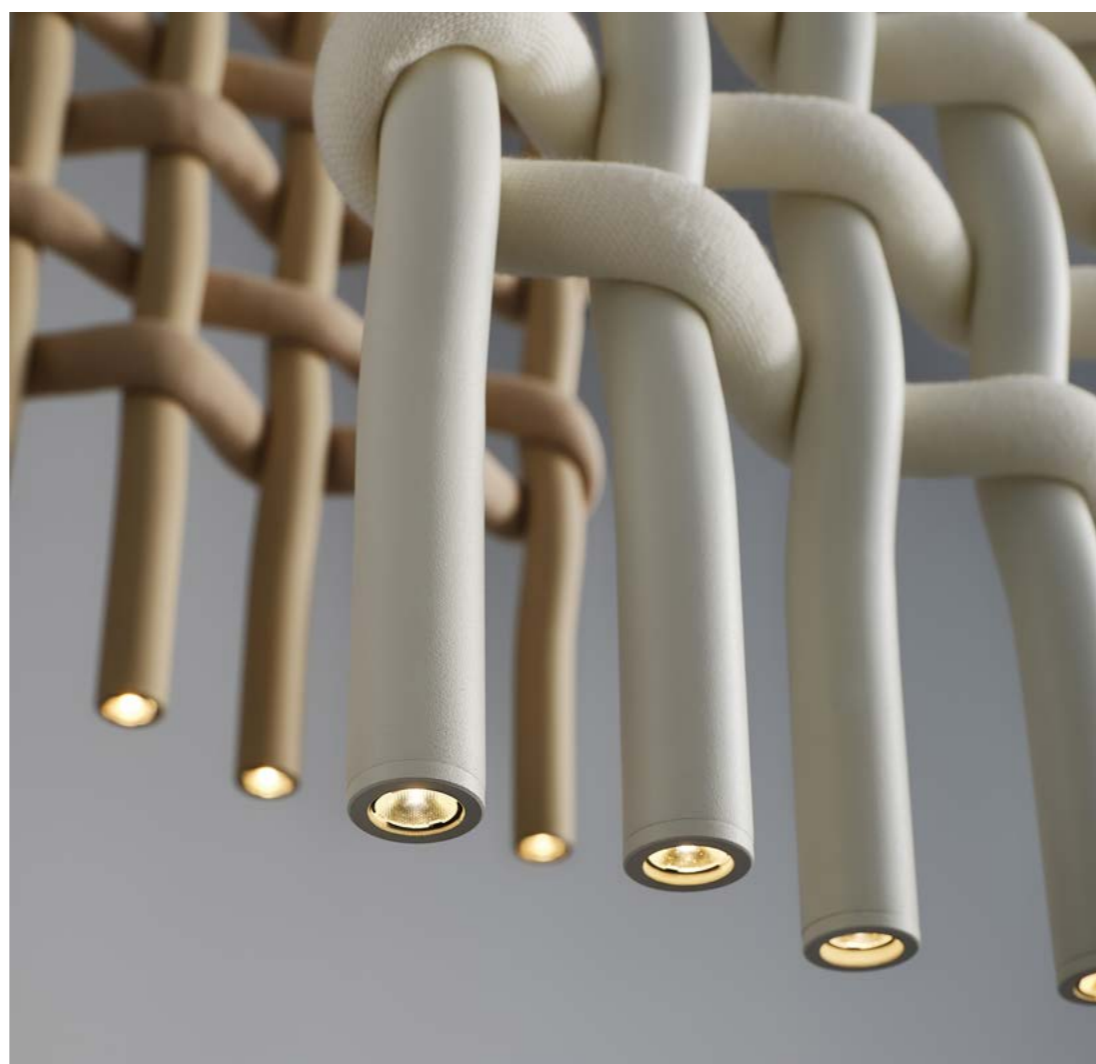
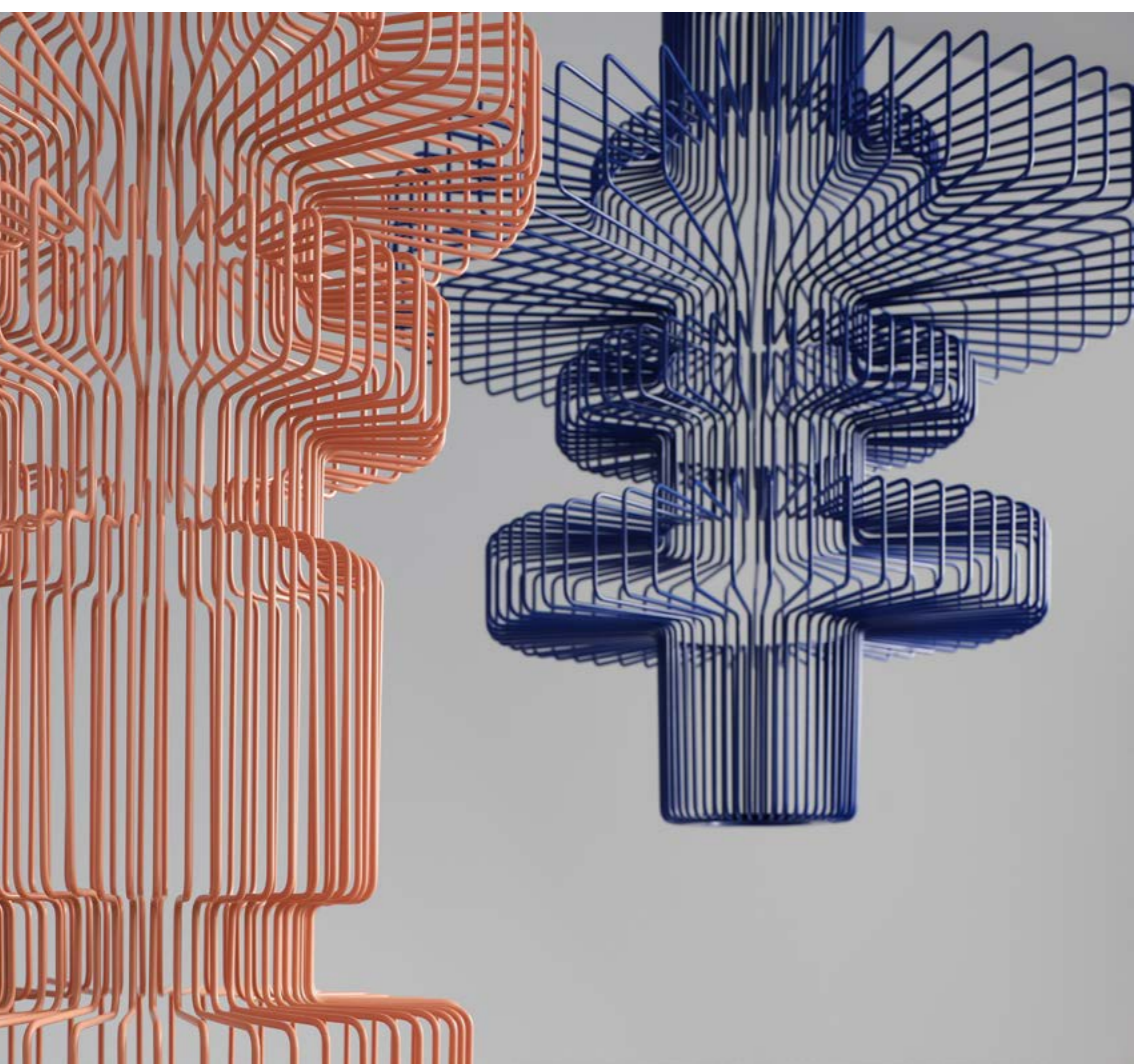

Design



Wire Medusa 75



Boya 79

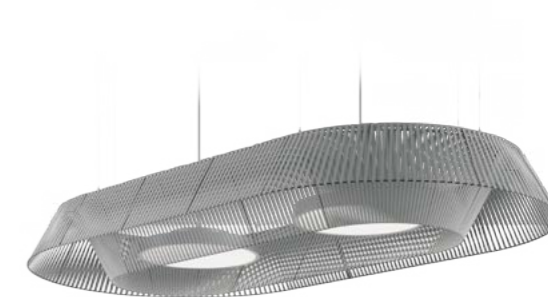

Ribbon 99



Jungle 85

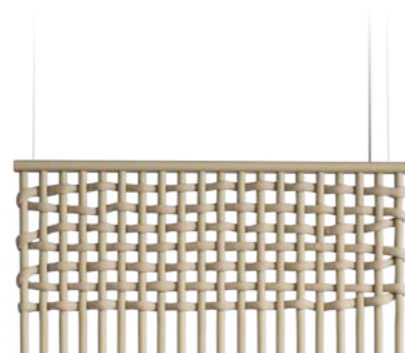

Blanket 89



Reloft 101



Loft One 103



Acoustic Team 95



Urban 105



Tube 107



reddot winner 2021

Wire Medusa

This product introduces new quality of visual and spatial experience in its class.

Wire medusa's form refers to the classic archetype of the chandelier.

A clear dimensional shape is composed of individual segments of bent wire. Despite its size it feels airy and light. The wire is bent perpendicularly. The parallax effect accentuated by the light emanating from the lamp's centre, creates a sculptural spectacle. It is an engaging experience in space. By moving around it, we can see the interplay of shapes and light. Shadows cast onto walls, give off a mysterious and sophisticated feel.

Every lampshade is made of identical segments that are arranged around the light source.





reddot winner 2021



Wire Medusa

EN

This light fixture offers a new quality of visual experience in its class. The shape of the Wire Medusa luminaire is based on a classic chandelier. The distinctive spacious shape consists of individual pieces of wire. Despite its size, it appears lightweight and open. The parallax effect, emphasized by the light emanating from the center of the lamp, creates a sculptural spectacle. As you walk around the lamp, you can see the interplay of shapes and light.

Wire Medusa was awarded the prestigious Red Dot Award: Product Design 2021

Designed by Kabo & Pydo – Design Studio

DE

Dieses Beleuchtungsprodukt führt eine neue Qualität der visuellen Eindrücke in seiner Klasse ein. Die Form der Wire Medusa-Lampe knüpft an klassische Kronleuchter an. Die klare räumliche Form besteht aus einzelnen Drahtelementen. Trotz ihrer Größe wirkt die Lampe leicht und einladend. Der Parallaxen-Effekt, der durch das aus der Mitte der Lampe ausgehende Licht verstärkt wird, schafft ein skulpturartiges Spektakel. Wenn Sie um die Lampe herumgehen, sehen Sie ein beeindruckendes Zusammenspiel von Formen und Licht.

Die Wire Medusa Leuchte wurde mit der prestigeträchtigen Auszeichnung Red Dot: Product Design 2021 ausgezeichnet

Entw. Kabo & Pydo – Design Studio

system power	12W
color temperature	3000K 4000K
electrical control	DIMM DALI ON/OFF
housing color	RAL color palette
mounting type	pendant
IP	IP20
CRI	>80
UGR	<19

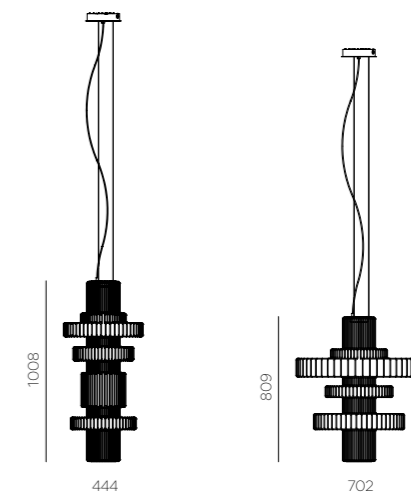



reddot winner 2021

Boya

Boya is a decorative hanging fitting. It may function as a single piece, but multiplied creates a pleasing collection. It is an exquisite mix of traditional handicraft and cutting-edge technology. When placed in the interior, it becomes its centerpiece, bringing a new level of elegance. Its light is soft and atmospheric, perfect for cosy spaces such as chill and lounge rooms.

The hanging system was designed to give the architects the freedom to compose it in dynamic arrangements, and nonchalant wiring gives it a playful character.

The warmth of the diffused light sets a calming, inviting mood to any space where the lamp is located.



reddot winner 2021

Boya

EN

Boya is a decorative pendant luminaire. It can be used as a single element or, when hung in a cluster, it can create an interesting constellation. It is a combination of handicraft and state-of-the-art technologies. The lamp shade is made in the traditional blown-glass technology. The suspended system is designed to give you the freedom to compose it in dynamic arrangements, while the nonchalant cabling adds to its character. The color of the glass and the cable wrap can be customized.

Boya was awarded the prestigious Red Dot Award 2021.

DE

Boya ist eine dekorative Hängelampe. Sie kann einzeln oder als interessantes Ensemble in mehrfacher Ausführung verwendet werden. Eine Kombination von Handwerk und modernster Technologie. Der Lampenschirm wird in traditioneller Technik aus geblasenem Glas hergestellt. Das Hängesystem ist so konzipiert, dass es die Möglichkeit bietet, die Lampe in dynamischen Arrangements zu komponieren, und die nonchalante Verkabelung trägt zu ihrem Charakter bei. Bei dieser Lampe können die Glasfarbe und das Kabelgeflecht farblich personalisiert werden.

Die Boya-Lampe erhielt die prestigeträchtige Red Dot Award 2021.

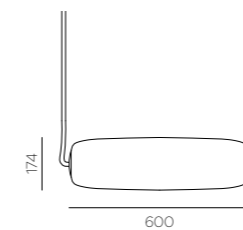

system power	18W
color temperature	3000K 4000K
electrical control	ON/OFF DIMM DALI
housing color	milky setta opal
suspension length	free
mounting type	pendant
IP	IP40
CRI	>80
UGR	<19



MILKY



SETTA



OPAL



reddot winner 2021

Shade finishings

Boya comes in 3 diverse shade finishings: milky, setta and opal (transparent black).

Boya

Jungle

This fitting brings more nature indoors, which is the main point of current biophilic design trends. Its innovation lies in being a lamp, and a plant holder at the same time. It looks best hanging in a group.

Simple form of a luminous vessel is a perfect background accentuating the beauty of the showstars – the plants themselves. The lamp emits delicate, silky smooth light, that sets a calming mood ideal for places like a chill out zone. The light and nature helps to relax.





Jungle

EN

This decorative lamp invites more nature into the interior, which is the primary goal of the biophilic design trend. It can be used both as a lamp and a plant pot. The simple form of the luminous vessel provides the perfect background to emphasise the beauty of the plant. The lamp emits a soft, silky-smooth light that creates a relaxing ambiance, perfect for such areas as chill-out zones. The luminaire is suspended on two bands of fabric, available in a wide range of colors. The rotomoulded lampshade makes the lamp completely waterproof.

DE

Dekorative Lampe, die einen Hauch von freier Natur in den Raum bringt, was das Hauptziel des Biophilic Design-Trends ist. Lampe und Blumentopf in einem. Die schlichte Form des leuchtenden Gefäßes ist ein perfekter Hintergrund, der die Pracht der Pflanze betont. Die Lampe strahlt ein weiches, seidenweiches Licht aus, das eine entspannende Atmosphäre schafft – die ideale Lösung für Orte wie die Chill-out-Zone. Die Leuchte ist an zwei Stoffstreifen aufgehängt, die in verschiedenen Farben bestellbar sind. Der rotationsgeformte Schirm macht die Lampe rundum wasserdicht.

system power	54W
color temperature	3000K 4000K
electrical control	ON/OFF DIMM DALI
housing color	white
mounting type	pendant
IP	IP40
CRI	>80
UGR	<19
stripes length	1m 2m 3m

STRIPES COLORS



* Original product colors may vary from those illustrated.

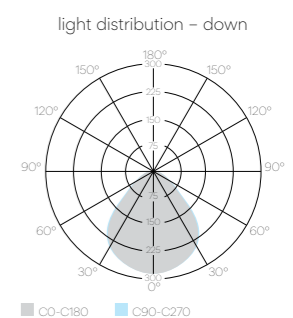
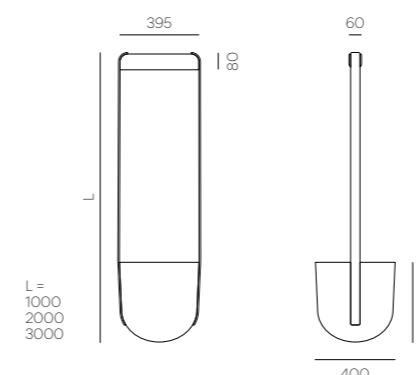

Blanket

Original lamp form resembles weaved fabric, but magnified to gigantic scale. Fabric's "warp" is made of bent aluminium tubes, and "weft" is made from thick, foam enhanced wool.

It's oversized structure was chosen specifically to divide space optically and acoustically. Areas divided by the lamp are not closed off completely, space can be sensibly manipulated, giving more privacy where it's needed.

Metal used for construction can be completely recycled.

The fitting comes preassembled, despite its large size, it is flat, which makes it easy to stack during transport.

The packaging is made of cardboard, and can be completely recycled.

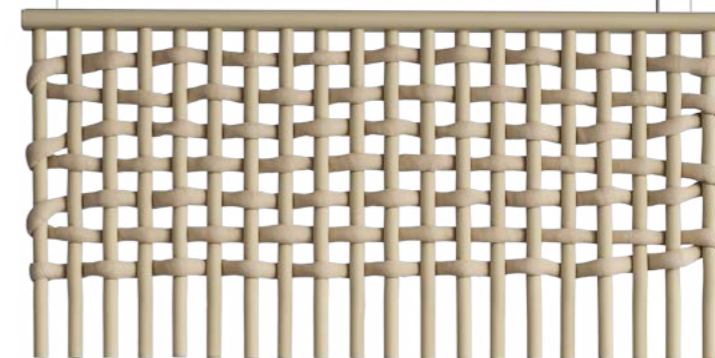
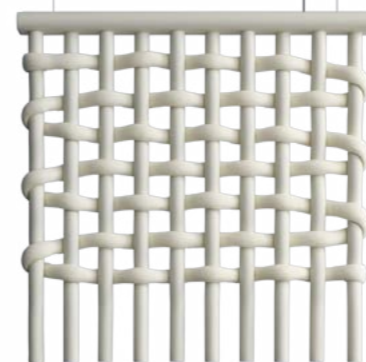
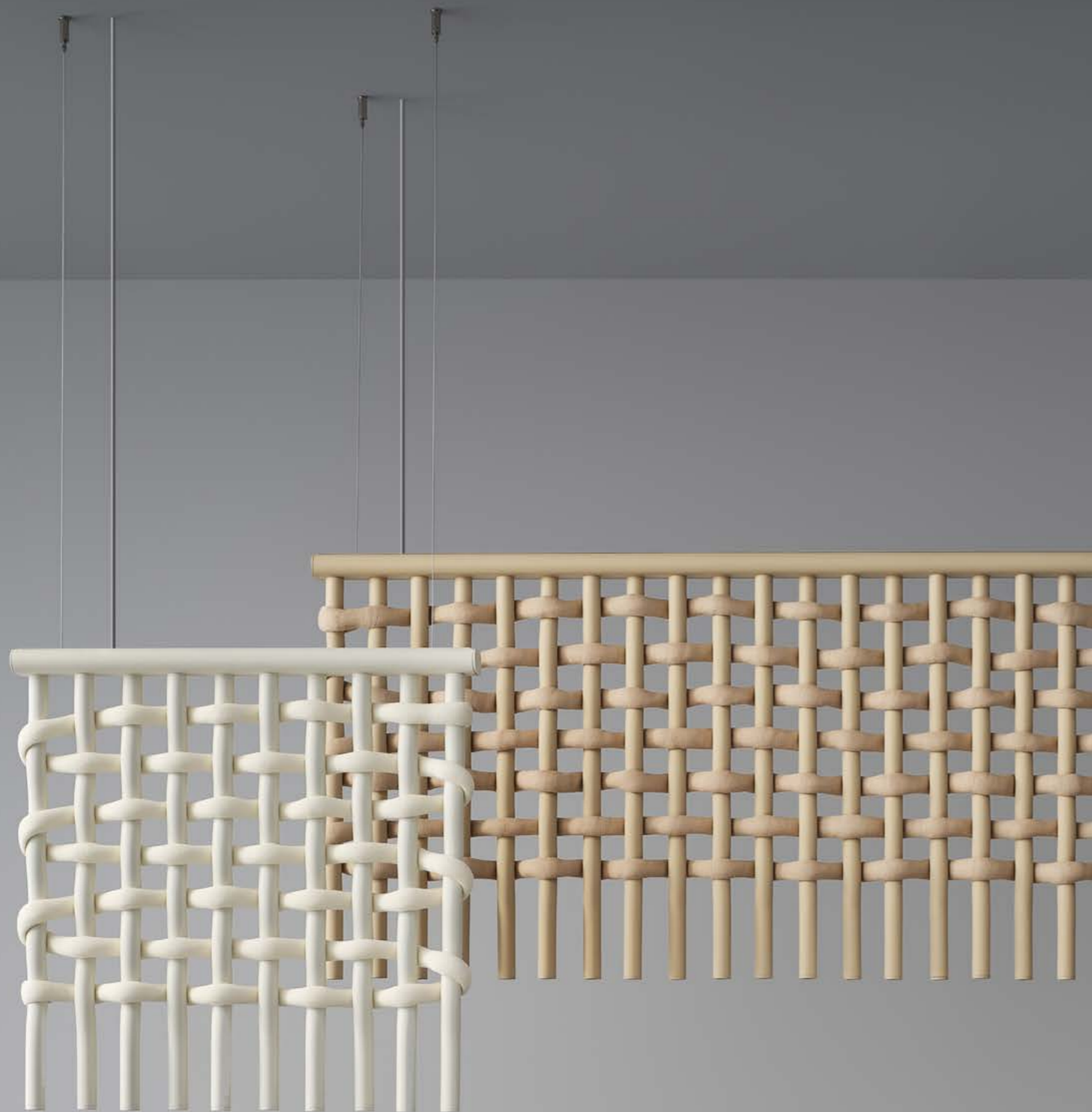

Blanket

EN

The lamp resembles fabric in texture but it has been enlarged to a giant scale. The “warp” is made of folded aluminum tubes and the “weft” is made of thick wool fortified with foam. This oversized lighting design has been specially chosen to allow for the division of optical and acoustic space. At the same time, it does not close the space completely, because it is open-work. When dimmed, it can be used to provide mood lighting in spaces for relaxing.

DE

Die Lampe erinnert in ihrer Struktur an Gewebe, jedoch in einem gigantischen Maßstab vergrößert. Der „Kettfaden“ des Gewebes besteht aus gebogenen Aluminiumrohren und der „Schuss“ aus dicker, mit Schaumstoff angereicherter Wolle. Diese maßstabsgetreue Beleuchtungsstruktur wurde gezielt gewählt, um eine optische und akustische Teilung des Raumes zu ermöglichen. Gleichzeitig verschließt sie ihn nicht vollständig, da sie durchbrochen ist. Gedimmt kann sie als Stimmungslicht in Chill Out-Zonen eingesetzt werden.

system power	15W Blanket 1195 x 595
	30W Blanket 595 x 595
color temperature	3000K
	4000K
electrical control	ON/OFF
	DIMM DALI
housing color	RAL color palette
mounting type	pendant
IP	IP20
CRI	>80
UGR	<19

RAL COLORS

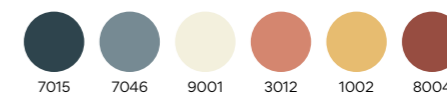

* Original product colors may vary from those illustrated.

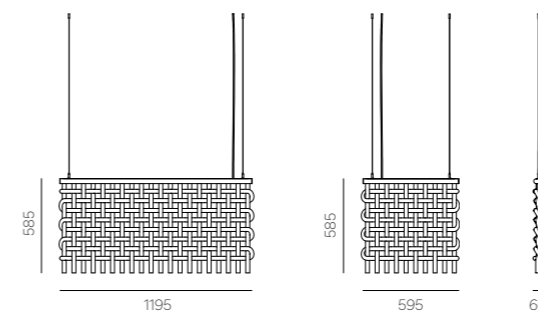



reddot winner 2021
best of the best

Acoustic Team

Acoustic Team is a system of four lamps with decorative accent lighting.

Its form enriches the interior by creating a cosy atmosphere, different forms and colors may be mixed together to create an eye-catching composition.

The fitting is perfect for spaces that will be enhanced by a piece that has a strong presence, and accentuates the mood with decorative light.

flexx

Configurations

These 3 segments allow to create various combinations adjusting it to our space.

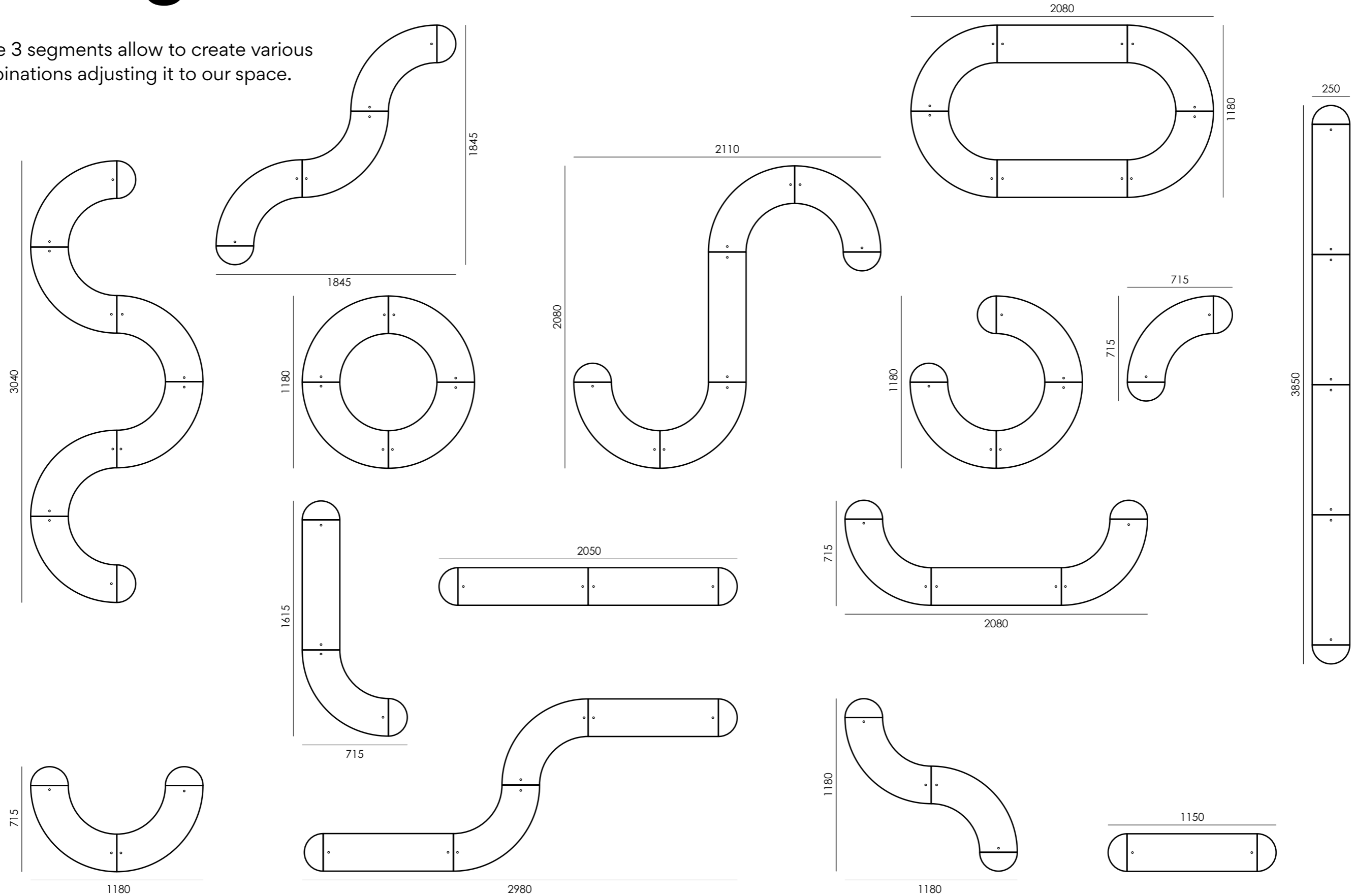



reddot winner 2021
best of the best



Acoustic Team

EN

A modular lamp made of three different components that can be combined in different ways. Thanks to the domed shade and the pressed fabric, the lamp absorbs some of the ambient sound. These features make it perfect for office environments, such as open-plan offices. Thanks to its excellent design, it creates a warm atmosphere in any interior. Recycled plastic bottles have been used to make the shade. The luminaire is available in two lighting options – for ambient lighting and for work. The color of the shade can be customized.

The lamp was awarded the Red Dot Award: Best of the Best 2021, designed by Kabo & Pydo – Design Studio.

DE

Modullampe mit drei verschiedenen Elementen, die beliebig kombiniert werden können. Die Kuppelform des Lampenschirms und das gepresste Material sorgen dafür, dass die Lampe einen Teil der Umgebungsgläusche absorbiert. Deshalb eignet sich das Modell perfekt für Büroarbeitsplätze, wie etwa in Open Space-Büros. Dank des ausgezeichneten Designs bringt sie eine warme Stimmung in den Raum. Bei der Herstellung des Lampenschirms wurden recycelte Plastikflaschen verarbeitet. Die Lampe ist in zwei Beleuchtungsvarianten erhältlich – als Deko-Leuchte und zur Arbeit. Möglichkeit zur Personalisierung der Farbe des Lampenschirms.

Die Lampe wurde mit der Auszeichnung Red Dot: Best of the Best 2021 ausgezeichnet, Entw. Kabo & Pydo – Design Studio.

color temperature	3000K
	4000K
electrical control	DIMM DALI
	ON/OFF
shade color	felt color palette
mounting type	pendant
IP	IP20
CRI	>80
UGR	<19

AVAILABLE COLORS

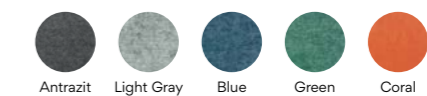

* Original product colors may vary from those illustrated.

Acoustical properties

The lamp serves as a sound absorber with excellent sound dampening properties. More than a half of the sounds that hit its surface are reduced.

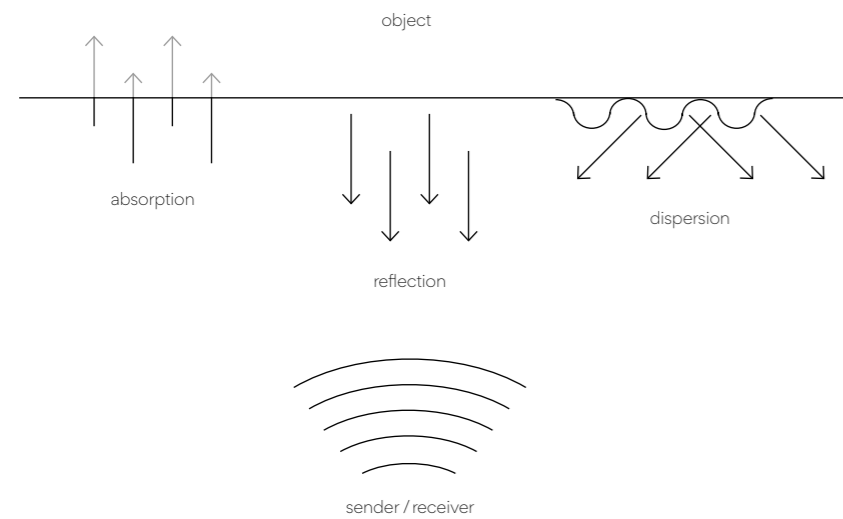

Noise or loud noises in the office can be controlled through absorption, which deals with reverberation in the space, making the space a better place to work. The acoustic properties of the fabrics used in the Acoustic Team are the ones that determine how the materials react to sound waves. Due to this and the shape of the lamp, the sound is partially absorbed and becomes quiet.



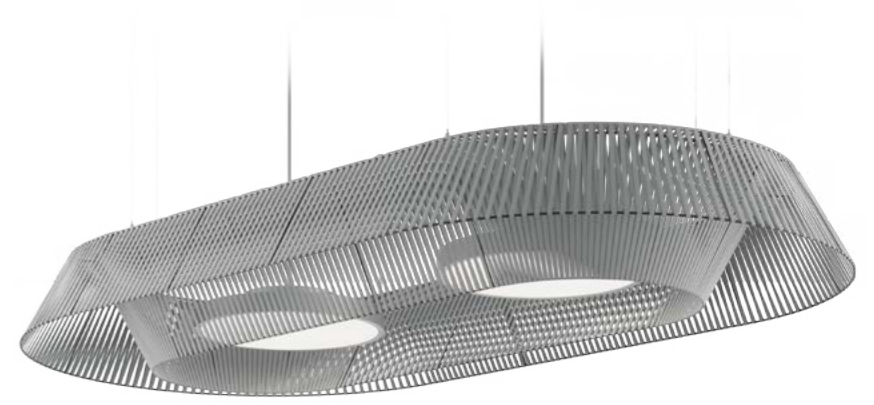
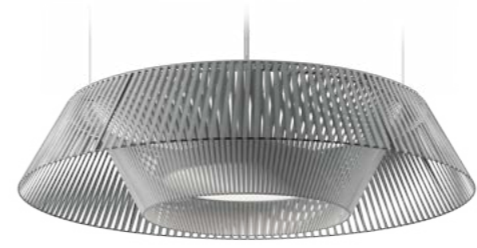

Ribbon

EN

The luminaires from this line were inspired by classic, woven lampshades. Due to its size, each of luminaires creates an intimate space. The lamp is filigree in details and vast in size. The luminaire is based on two shades, external and internal. The whole is based on a welded structure made of powder-coated steel rods. Customers can choose from a luminaire in the shape of a circle or a rectangle with rounded corners.

DE

Inspiration für die Leuchten dieser Linie waren klassische, gewebte Lampenschirme. Jede der Leuchten definiert aufgrund ihrer Größe einen intimen Raum. Die Leuchte ist filigran im Detail und maßgebend in der Größe. Die Leuchte basiert auf zwei Lampenschirmen – einem äußeren und einem inneren. Das Ganze basiert auf einer Schweißkonstruktion aus pulverbeschichteten Stahlstäben. Kunden können eine Leuchte auf Basis eines Kreises oder eines Rechtecks mit abgerundeten Ecken wählen.

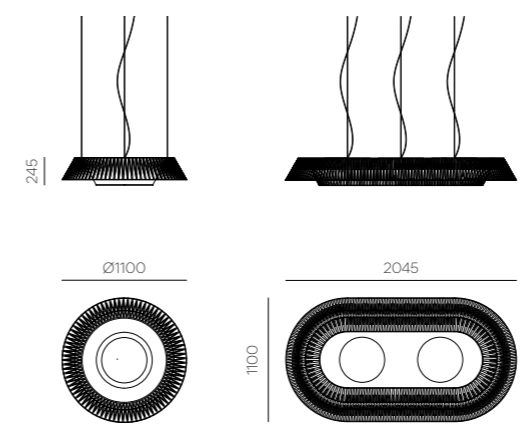

system power	30W Ribbon 1100×245
	2×30W Ribbon 2045×1110×245
light distribution - up	100°
light distribution - down	95°
color temperature	3000K
	4000K
	6000K
	TUNABLE WHITE
electrical control	1-10V
	DIMM DALI
	1-10V tunable white motion + daylight sensor
	ON/OFF
housing color	white
	black
	RAL color palette
shade color	ribbon color palette
mounting type	pendant
IP	IP20
CRI	>80
UGR	<18

COLORS

306	287	267	338	425	212
427	240	446	319	447	316

* Original product colors may vary from those illustrated.

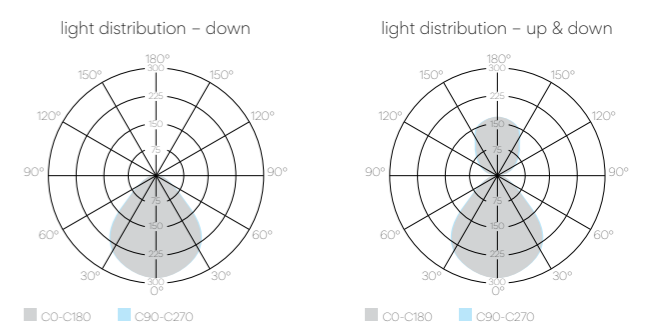



Reloft

EN

The industrial lamp by Mesko from the 1970s renovated to both provide light for office spaces and serve as a decorative interior element. The lamp shade has been sandblasted and repainted, which gives it more character without damaging the original form. A microprism diffuser has been added to the bottom to provide comfortable lighting.

Bring a loft feel to your design with our lamp.

DE

Industrielampe der Firma Mesko aus den 1970er Jahren, die nach der Restaurierung sowohl Büroräume beleuchten, als auch als Deko-Lampe eingesetzt werden kann. Der Lampenschirm wurde sandgestrahlt und neu lackiert, was der Lampe Charakter verleiht, ohne die ursprüngliche Form zu zerstören. An der Unterseite wurde eine mikroprismatische Blende angebracht, um eine komfortable Beleuchtung zu gewährleisten.

Verleihen Sie Ihrem Projekt dank unserer Lampe echtes Loft-Flair.



system power	44W
color temperature	3000K 4000K
electrical control	1-10V DIMM DALI 1-10V tunable white motion + daylight sensor ON/OFF
housing color	black RAL color palette
mounting type	pendant
IP	IP20
CRI	>80
UGR	<19

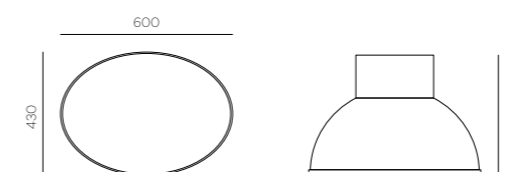

light distribution - down

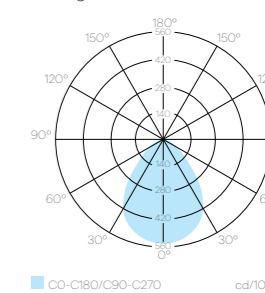



Loft One

EN

This minimalist pendant light in a contemporary, loft style features a single COB light source. The simple industrial form is perfect for both public and private spaces. The high quality workmanship and attention to detail will satisfy the most demanding customer. In addition, you can choose the color of the luminaire and the wire, the light color and the power supply method.

DE

Minimalistische Hängelampe im modernen Loft-Stil, mit einer einzigen COB-Lichtquelle. Die schlichte industrielle Form ist sowohl für öffentliche Räumlichkeiten als auch für Privaträume ideal geeignet. Die hochwertige Ausführung und Liebe zum Detail stellen auch anspruchsvollste Kunden zufrieden. Zusätzlich besteht die Möglichkeit, die Farbe von Gehäuse und Kabel sowie die Lichtfarbe und die Energiequelle zu wählen.



system power	15W
color temperature	3000K 4000K
electrical control	1-10V DIMM DALI ON/OFF
housing color	black RAL color palette
mounting type	pendant
IP	IP20
CRI	>80
UGR	<19

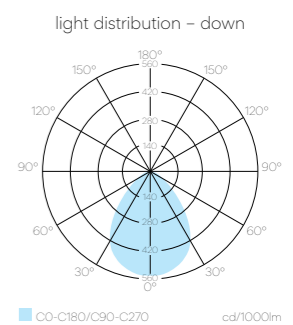
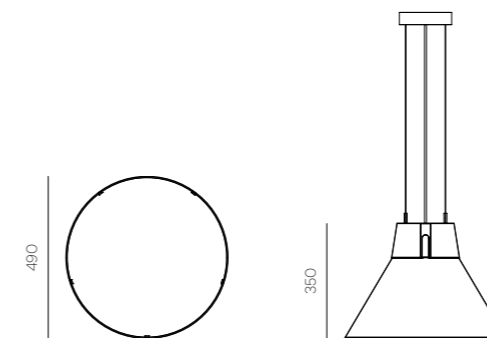



Urban

EN

Industrial linear lamp made of aluminum, mounted to the ceiling with cables as a pendant lamp. Flexx Urban features an attractive design, quick assembly and a low glare value of UGR<19. As an option, it can be controlled with the DALI control system. Made from high quality components from the best European manufacturers. The unique loft design and attention to detail will satisfy the most demanding customers. The product is perfect for offices, conference rooms, and passageways.

DE

Industrielle Langfeldleuchte aus Aluminium, mit Drähten als Pendelleuchte an der Decke montiert. Flexx Urban zeichnet sich durch das ästhetische Design, die schnelle Montage und eine geringe Blendung UGR<19 aus. Optionale DALI-Steuerung. Hergestellt aus hochwertigen Komponenten von besten europäischen Herstellern. Das einzigartige Loft-Design und die Liebe zum Detail stellen auch die anspruchsvollsten Kunden zufrieden. Das Produkt eignet sich perfekt für Büroräume, Konferenzsäle und Flure.



system power	40W
color temperature	3000K 4000K
electrical control	1-10V DIMM DALI ON/OFF
housing color	silver RAL color palette
mounting type	pendant
IP	IP20
CRI	>80
UGR	<19

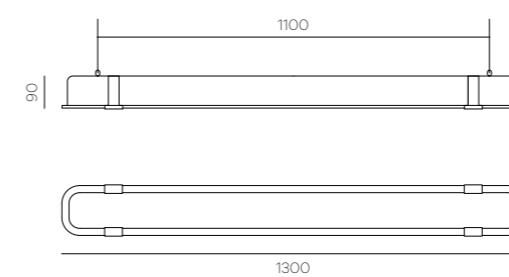

light distribution - down

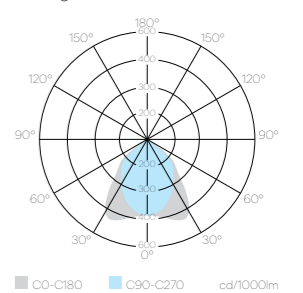



BRAIN EMBASSY mode:lina

Tube

EN

The modern Flexx Tube luminaire with a unique design. The shape of a transparent tube with visible technical elements gives it an industrial, loft appearance. It is characterized by high quality workmanship, the best components of European production, easy assembly and interesting design. Perfect for indoor use, especially in offices and public utility buildings.

DE

Moderne Flexx Tube Leuchte mit einzigartiger Konstruktion. Die transparente Röhrenform mit sichtbaren technischen Elementen verleiht ihr einen industriellen, loftähnlichen Stil. Das Modell zeichnet sich durch hohe Ausführungsqualität, beste Komponenten europäischer Herstellung, die einfache Montage und ein interessantes Design aus. Die ideale Lösung für Innenräume und insbesondere für Büros und öffentliche Gebäuden.



system power	47W
color temperature	3000K 4000K
electrical control	1-10V DIMM DALI ON/OFF
housing color	silver RAL color palette
mounting type	pendant
IP	IP20
CRI	>80
UGR	<18

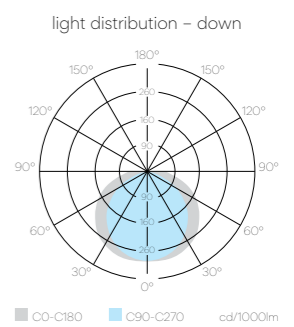

**What do you
think of our
#RedDot
light fixtures?**

Profiles & system luminaires.

Flexx Line

Flexx Line means the power of personalisation. Do you want to cover a part of your profile with a blind? No problem! A specific length? – Easy. A geometric system? – No challenge for us. Use your imagination and create unique lighting systems with our help.



CLARIANT THE DESIGN GROUP

Flexx Line 43

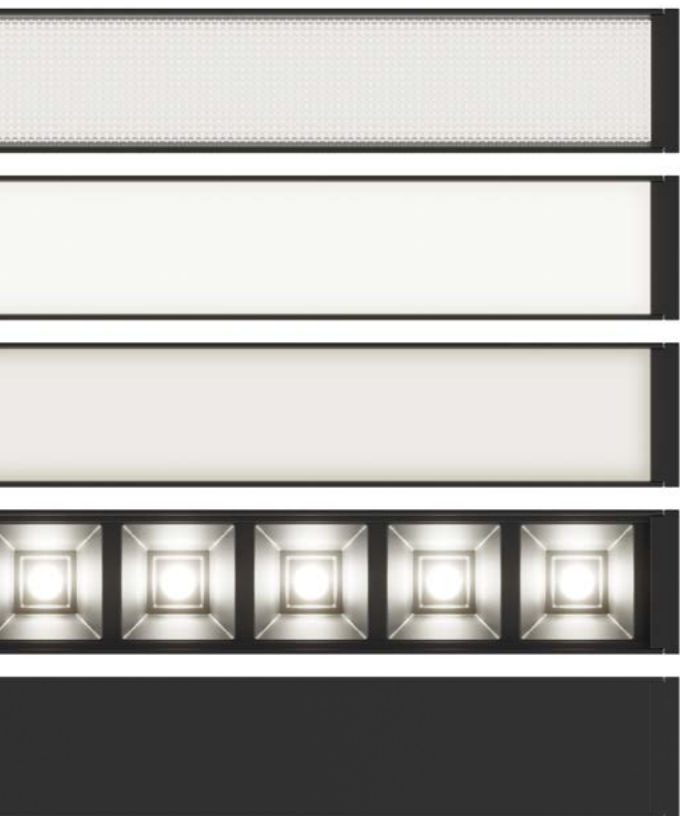

MICROPRISMATIC

OPAL

DARK OPAL

DARK OPTIC

BLIND COVER

flexx

Flexx Line 28



MICROPRISMATIC

OPAL

DARK OPTIC

BLIND COVER

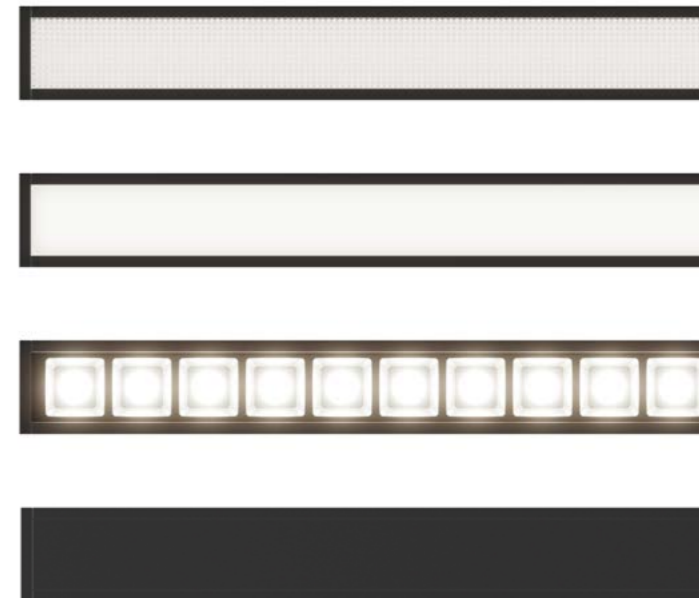

flexx



black

white

silver

gold

EN

The optics of a luminaire are incredibly important. It's what allows us to tailor our product to your needs. Whether you are looking for excellent working conditions, high luminaire efficiency or special aesthetics, you will find something suitable. Four types of optics – endless possibilities.

DE

Die Optik des Rahmens ist unglaublich wichtig. Dank ihr können wir unser Produkt an die Bedürfnisse des Anwenders anpassen. Ob Sie hervorragende Arbeitsbedingungen, eine hohe Effizienz der Leuchte oder besondere ästhetische Qualitäten suchen, Sie werden etwas Passendes finden. Vier Arten von Optiken – unendliche Möglichkeiten.



EN

You are free to choose the right size of product to suit the needs of your projects. The product comes in two versions 28 and 43.

DE

Sie können die Größe des Produkts frei wählen, um es an die Bedürfnisse Ihrer Projekte anzupassen. Das Produkt gibt es in zwei Ausführungen 28 und 43.

DARK OPAL
OFF

DARK OPAL
ON

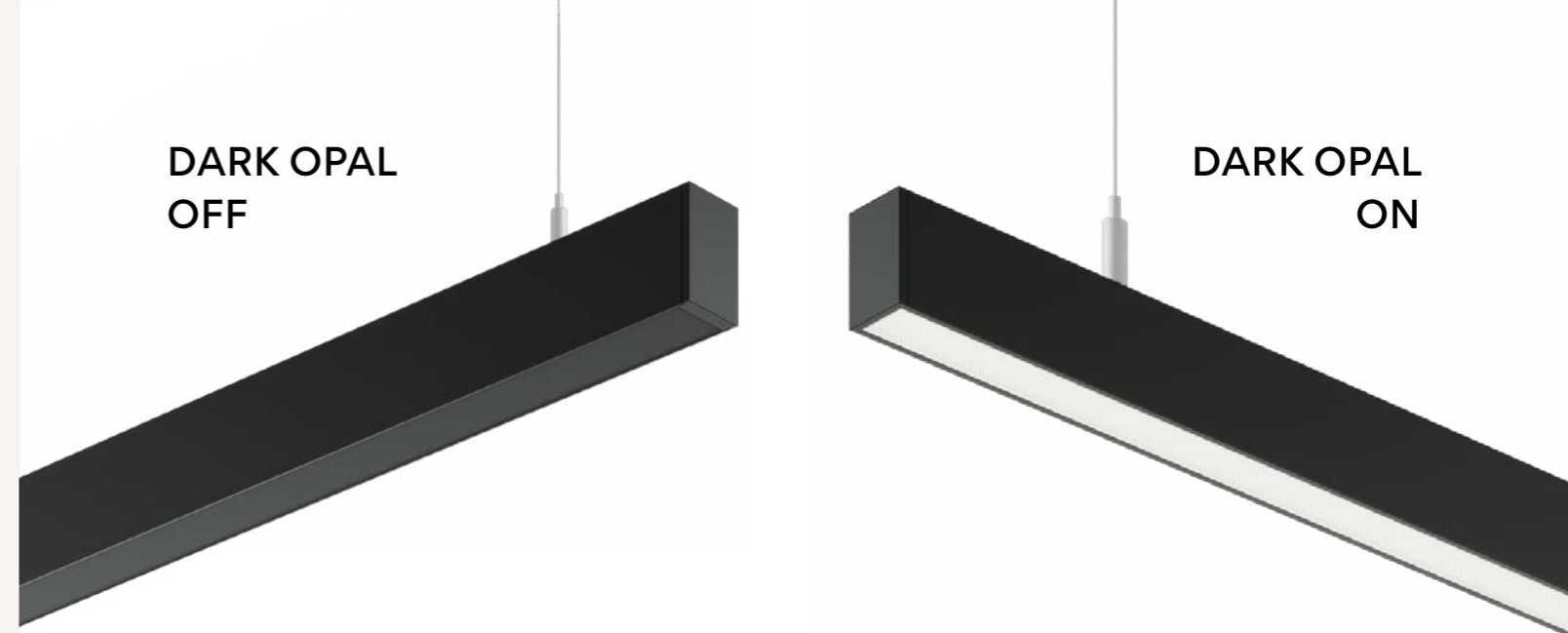

The dark optics are a minimalist version of the optics that look unique even when the light is off.

EN

You are free to choose the right size of product to suit the needs of your projects. The product comes in two versions 28 and 43.

DE

Dunkle Optiken sind eine minimalistische Version von Optiken, die auch bei ausgeschaltetem Licht einzigartig aussehen.



Flexx Line 43

EN

Profile-type of housing made of an aluminum profile with an LED light source, suitable for pendant and surface mounting. The luminaire is available with a choice of milky, microprism, opal or dark opal diffuser. The housing can be painted any color from the RAL palette. The high quality of workmanship and the excellent light characteristics of this lamp make it ideal for use in offices, shopping venues, galleries and museums.

DE

Profilleuchte aus Aluminiumprofil mit LED-Lichtquelle, für Hänge- und Aufputzmontage geeignet. Die Lampe ist nach Wahl mit einer der folgenden Blenden erhältlich: Milchglas, Mikroprisma, Opal oder Dark Opal. Das Gehäuse kann in jeder RAL-Farbe lackiert werden. Die hohe Ausführungsqualität und die ausgezeichneten Beleuchtungsparameter machen das Modell zur perfekten Wahl für Büros, Geschäftsräume und Einkaufszentren, Galerien und Museen.



system power	30W
	35W
	40W
light distribution	direct
	indirect
	direct / indirect
color temperature	3000K
	4000K
	TUNABLE WHITE
current	100 - 149mA
	150 - 199mA
	200 - 350mA
	360 - 500mA
	510 - 700mA
electrical control	1-10V
	DIMM DALI
	1-10V tunable white motion + daylight sensor
	ON/OFF
mounting type	pendant
	recessed
	surface
	suspended
IP	IP20
CRI	>80
UGR	<19

HOUSING COLOR

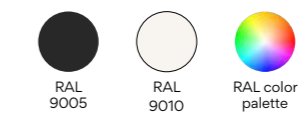

OPTICS

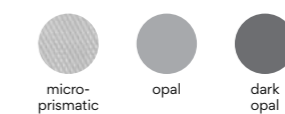

DARK OPTICS

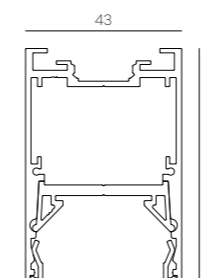



Flexx Line 28

EN

Profile housing in the mini version, profile width is 28 mm. Made of high-quality components, available in surface-mounted and pendant versions. The housing can be painted any RAL color, the light sources available: 3000K, 4000K as well as TUNABLE WHITE. It is equipped with the DAISY diffuser, available in different colors. The high quality of workmanship and the excellent light characteristics of this lamp make it ideal for use in offices, shopping venues, galleries and museums.

DE

Profilleuchte in Mini-Ausführung, Profilbreite 28 mm. Hergestellt aus hochwertigen Komponenten, in Aufputz- und Hängeversion erhältlich. Das Gehäuse kann in jeder RAL-Farbe lackiert werden. Lichtquelle 3000K, 4000K oder TUNABLE WHITE zur Wahl. Ausgestattet mit DAISY-Blende, die in verschiedenen Farben erhältlich ist. Die hohe Ausführungsqualität und die ausgezeichneten Beleuchtungsparameter machen das Modell zur perfekten Wahl für Büros, Geschäftsräume und Einkaufszentren, Galerien und Museen.



system power	30W
	35W
	40W
light distribution	direct
	indirect
	direct / indirect
color temperature	3000K
	4000K
	TUNABLE WHITE
electrical control	1-10V
	DIMM DALI
	1-10V tunable white motion + daylight sensor
	ON/OFF
mounting type	pendant
	recessed
	surface
	suspended
IP	IP20
CRI	>80
UGR	<19

HOUSING COLOR

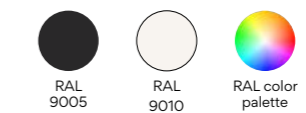

OPTICS

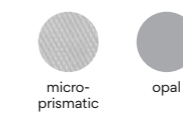

DARK OPTICS

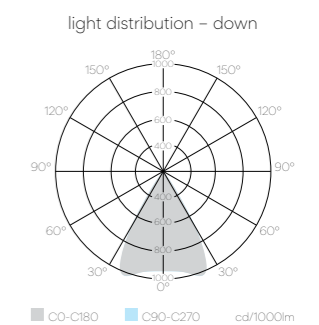
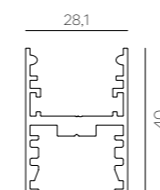

**Lighting
design
for you.**

3,2,1...

**#professional
luminaires.**

Professional



Rectangle Panel 129



Circly 131



Double Line 137



Quadrat Panel 139

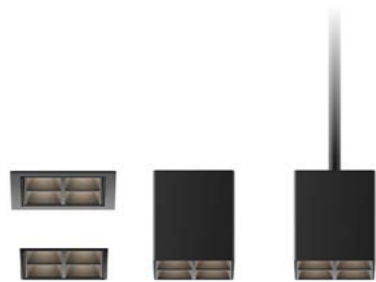

Cube 133



Nola 135



Backlit 141



Rectangle Panel

EN

A state-of-the-art LED panel with a power of 36W and a light temperature of 3000K or 4000K to choose from. Rectangle Panel features an attractive design, quick assembly and a low-glare value of UGR<19. This panel is used as ceiling lighting in office buildings, restaurants and hotels, the industry and residential buildings.

DE

Modernes LED-Panel mit einer Leistung von 36W und einer Lichtfarbe von 3000 und 4000K. Rectangle Panel zeichnet sich durch eine ästhetische Optik, die schnelle Montage und eine geringe Blendung UGR<19 aus. Das Panel eignet sich als Deckenbeleuchtung in Bürogebäuden, Gastronomie und Hotellerie, Industrie sowie in Wohngebäuden.



system power	36W
light distribution - down	120°
color temperature	3000K
	4000K
	5700K
electrical control	1-10V
	DIMM DALI
	ON/OFF
housing color	white
	black
	grey
mounting type	pendant
	recessed
IP	IP44
CRI	>80
UGR	<19

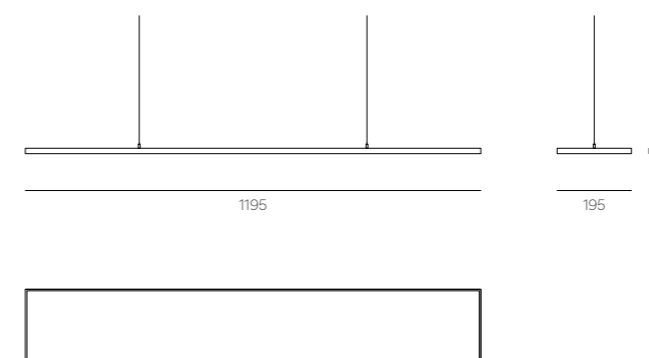

light distribution - down

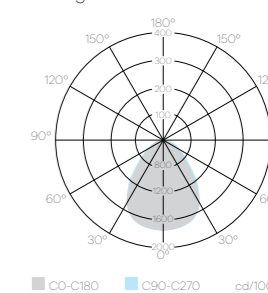



SHOWROOM HUMAN OFFICE

Circly

EN

A classic ceiling luminaire designed for office interiors. The circular, universal shape of Circly ensures wide use in interiors designed in various styles. It provides excellent working conditions thanks to the microprismatic cover. Moreover, the discreet light distribution upwards allows for uniform ceiling lighting. The luminaire allows using the DALI module.

DE

Eine klassische Deckenleuchte für Büroeinrichtungen. Die kreisförmige, universelle Form von Circly sorgt für eine breite Verwendung in Innenräumen, die in verschiedenen Stilen gestaltet sind. Dank der mikroprismatischen Abdeckung bietet sie hervorragende Arbeitsbedingungen. Darüber hinaus ermöglicht die diskrete Lichtverteilung nach oben eine gleichmäßige Deckenbeleuchtung. Es ist möglich, das DALI-Modul in der Leuchte zu verwenden.

system power	30W Circly Ø450
	48W Circly Ø600
light distribution - up	100°
light distribution - down	95°
color temperature	3000K
	4000K
	6000K
	TUNABLE WHITE
electrical control	1-10V
	DIMM DALI
	1-10V tunable white motion + daylight sensor
	ON/OFF
housing color	white
	black
	silver
mounting type	pendant
IP	IP20
CRI	>80
UGR	<18

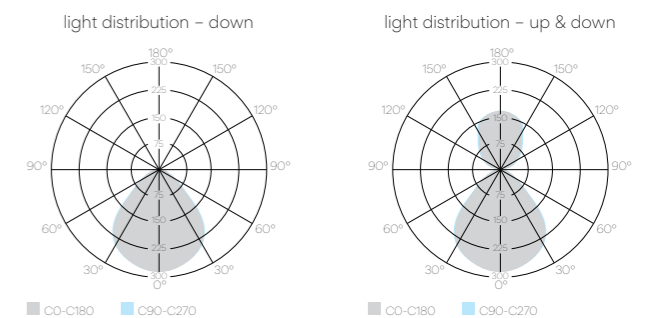



Cube

EN

A classic ceiling luminaire designed for office interiors. The circular, universal shape of Circly ensures wide use in interiors designed in various styles. It provides excellent working conditions thanks to the microprismatic cover. Moreover, the discreet light distribution upwards allows for uniform ceiling lighting. The luminaire allows using the DALI module.

DE

Eine klassische Deckenleuchte für Büroeinrichtungen. Die kreisförmige, universelle Form von Circly sorgt für eine breite Verwendung in Innenräumen, die in verschiedenen Stilen gestaltet sind. Dank der mikroprismatischen Abdeckung bietet sie hervorragende Arbeitsbedingungen. Darüber hinaus ermöglicht die diskrete Lichtverteilung nach oben eine gleichmäßige Deckenbeleuchtung. Es ist möglich, das DALI-Modul in der Leuchte zu verwenden.

system power	16W
light distribution - down	80°
color temperature	3000K 4000K TUNABLE WHITE
electrical control	1-10V DIMM DALI 1-10V tunable white motion + daylight sensor ON/OFF
housing color	black RAL color palette
mounting type	recessed with frame recessed without frame pendant
IP	IP20
CRI	>80
UGR	<19

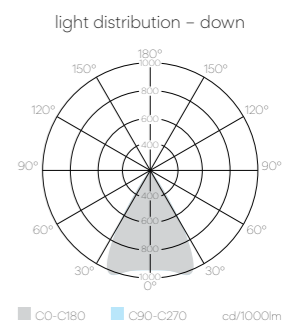
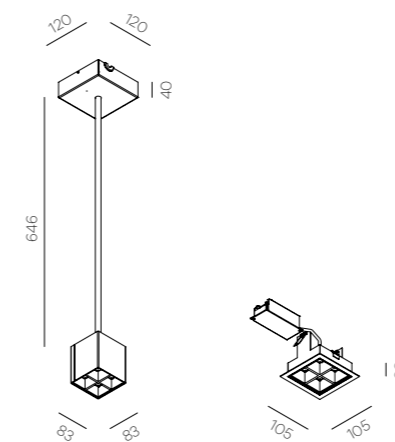



Nola

EN

The Nola surface-mounted lamp is a premium product with a simple, modern design. By default, it comes in two color housing versions of: black and white, but as an option it can also be powder-coated in any RAL color of your choice. The reflector is available in black, white, gold and silver. The Nola luminaire is made from high-quality European-made components (COB LED, power supply) and easy assembly is an additional advantage. It is perfect as lighting in offices, passageways, open spaces, shopping facilities, galleries and museums.

DE

Die Aufputzleuchte Nola ist ein Produkt der Premium-Klasse mit schlichtem, modernem Design. Standardmäßig ist sie in zwei Gehäusefarben erhältlich: Schwarz und Weiß, optional kann sie aber auch in jeder anderen RAL-Farbe pulverbeschichtet werden. Der Reflektor ist in folgenden Farben erhältlich: Schwarz, Weiß, Gold und Silber. Die Nola-Leuchte besteht aus hochwertigen Komponenten europäischer Herstellung (COB-Led, Netzgerät) und überzeugt durch die einfache Montage. Sie eignet sich hervorragend zur Beleuchtung von Büros, Fluren, Open Space-Flächen, Geschäftsräumen und Einkaufszentren, Galerien und Museen.

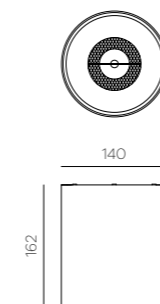

system power	20W
color temperature	2700K 3000K 4000K TUNABLE WHITE
electrical control	1-10V DIMM DALI 1-10V tunable white motion + daylight sensor ON/OFF
housing color	white black RAL color palette
reflector color	white black silver gold
mounting type	pendant surface
IP	IP20
CRI	>80
UGR	<19

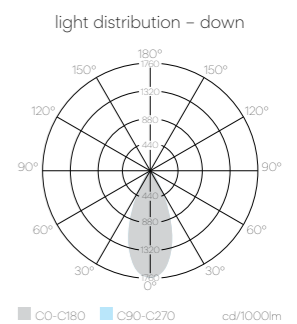



Double Line

EN

Modern 60×60 lighting fixture with a high-performance LED light source. Double Line features an attractive design, quick assembly and a low UGR. As an option, it can be controlled with the DALI control system. The housing is made of steel sheet, powder-coated and a microprism diffuser. The product is perfect for offices, conference rooms, and passageways.

DE

Moderne Leuchte im Standard 60×60, mit LED-Lichtquelle mit hohen Beleuchtungsparametern. Double Line zeichnet sich durch das ästhetische Design, die schnelle Montage und eine geringe UGR-Blendung aus. Optionale DALI-Steuerung. Das Gehäuse besteht aus pulverbeschichtetem Stahlblech und einer mikroprismatischen Blende. Das Produkt eignet sich perfekt für Büroräume, Konferenzsäle und Flure.

system power	30W
	35W
	45W
color temperature	3000K
	4000K
electrical control	1-10V
	DIMM DALI
	ON/OFF
housing color	white
mounting type	pendant
	ceiling
IP	IP20
CRI	>80
UGR	<19

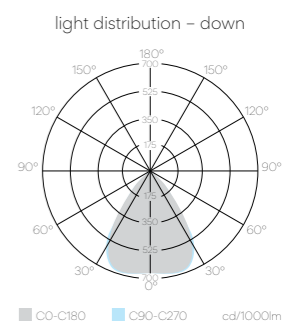
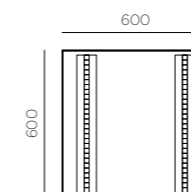



Quadrat Panel

EN

LED panel with a white aluminum frame, with a power of 36W and 40W and dimensions of 595×595. Quadrat Panel boasts quick assembly in suspended ceilings, even illumination and high light performance. This luminaire is perfect for offices, hotels and other facilities that require very good lighting thanks to professional, strong LEDs that maintain an excellent, wide light output and a high color rendering index of CRI/Ra>80.

DE

LED-Panel mit weißem Aluminiumrahmen, mit einer Leistung von 36W und 40W, Maße 595×595. Das Modell Quadrat Panel zeichnet sich durch die schnelle Montage an untergehängten Decken, eine gleichmäßige Leuchtdichte und sehr gute Beleuchtungsparameter aus. Dank der professionellen und leistungsstarken LED-Dioden mit sehr breitem Lichtstrom und hohem Farbwiedergabeindex (CRI/Ra>80) eignet sich die Leuchte hervorragend für Büros, Hotels und andere Einrichtungen, die eine sehr gute Beleuchtung benötigen.

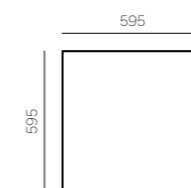

system power	36W
	40W
light distribution - down	90°
color temperature	3000K
	4000K
	5700K
electrical control	1-10V
	DIMM DALI
	ON/OFF
housing color	white
mounting type	pendant
IP	IP40
CRI	>80
UGR	<19

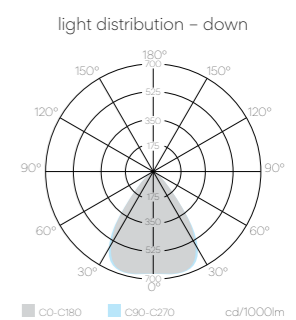



Backlit

EN

Luminaire with a white aluminum frame, with a power of 36W, 40W, 45W and dimensions of 595x595. Backlit boasts quick assembly in suspended ceilings, even illumination and high light performance. This luminaire is perfect for offices, hotels and other facilities that require very good lighting thanks to professional, strong LEDs that maintain an excellent, wide light output and a high color rendering index of CRI/Ra>80.

DE

Leuchte mit weißem Aluminiumrahmen, mit einer Leistung von 36W, 40W, 45W, Maße 595x595. Das Modell Backlit zeichnet sich durch die schnelle Montage an untergehängten Decken, eine gleichmäßige Leuchtdichte und sehr gute Beleuchtungsparameter aus. Dank der professionellen und leistungsstarken LED-Dioden mit sehr breitem Lichtstrom und hohem Farbwiedergabeindex (CRI/Ra>80) eignet sich die Leuchte hervorragend für Büros, Hotels und andere Einrichtungen, die eine sehr gute Beleuchtung benötigen.

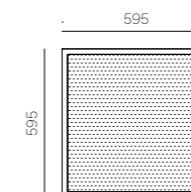

system power	30W
	35W
	45W
light distribution - down	90°
color temperature	3000K
	4000K
electrical control	1-10V
	DIMM DALI
	ON/OFF
housing color	white
mounting type	pendant
	ceiling
IP	IP20
CRI	>80
UGR	<19

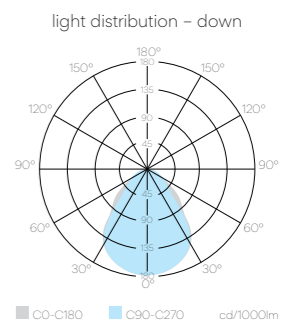

**Got an idea?
We can design
lighting fixtures
together!**

We are #flexx.

Floor and table luminaires.

Movy

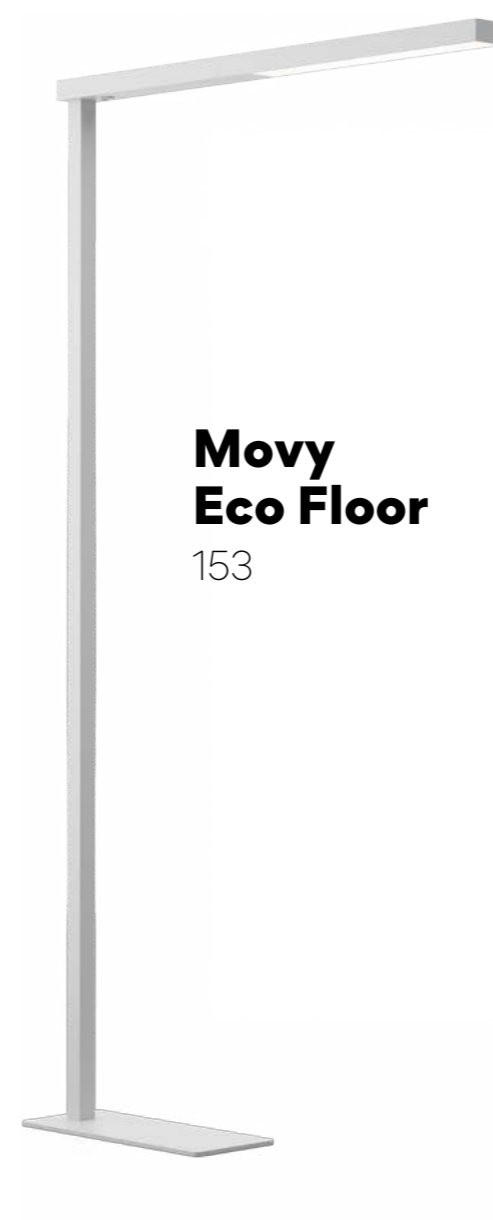



SHOWROOM HUMAN OFFICE

Movy Pro Floor

EN

Individual floor lamp with micro-reflector and anti-glare cover. The aluminium body of the luminaire and the steel stand with a recess for the desk base allow the lamp to be moved freely. Control the intensity and color of the light with the touch panel, following the rhythm of the day and your taste. The lamp has a built-in motion and daylight sensor. The lamp has a connection cable and a safety plug. Powder-coated lamp in white, grey or black. Light distribution suitable for the workplace with excellent glare reduction (UGR < 10).

DE

Individuelle Stehlampe mit Mikroreflektor und Blendschutz. Der Aluminiumkörper der Leuchte, ein Stahlsockel mit einer Aussparung für das Schreibtischgestell, ermöglicht das problemlose Umstellen der Lampe. Steuern Sie Intensität und Farbe des Lichts mithilfe eines individuellen Touchpanels entsprechend der Tageszeit und Ihrer Vorlieben. Die Lampe verfügt über einen eingebauten Bewegungs- und Tageslichtsensor. Die Lampe ist mit einem Verbindungskabel mit Sicherheitsstecker ausgestattet. Pulverbeschichtet (weiß, grau oder schwarz). Für den Arbeitsplatz geeignete Lichtverteilung mit hervorragender Blendungsbegrenzung (UGR < 10).

system power	80W
light distribution - up	140°
light distribution - down	80°
	50°
color temperature	3000K - 6000K
electrical control	1-10V tunable white motion + daylight sensor
housing color	white
	gray
	black
mounting type	floor
IP	IP20
CRI	>80
UGR	<12

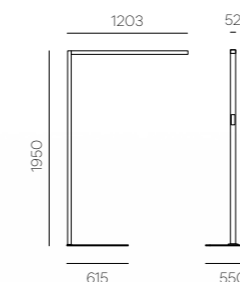

light distribution - up & down

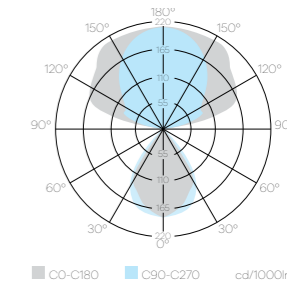

■ C0-C180 ■ C90-C270 cd/1000lm

flexx



SHOWROOM HUMAN OFFICE

Movy Standard Floor

EN

Individual floor lamp with micro-reflector and anti-glare cover. The aluminium body of the luminaire and the steel stand with a recess for the desk base allow the lamp to be moved freely. Control the intensity and color of the light with the touch panel, following the rhythm of the day and your taste. The lamp has a built-in motion and daylight sensor. The lamp has a connection cable and a safety plug. Powder-coated lamp in white, grey or black. Light distribution suitable for the workplace with excellent glare reduction (UGR < 6).

DE

Individuelle Stehlampe mit Mikroreflektor und Blendschutz. Der Aluminiumkörper der Leuchte, ein Stahlsockel mit einer Aussparung für das Schreibtischgestell, ermöglicht das problemlose Umstellen der Lampe. Steuern Sie Intensität und Farbe des Lichts mithilfe eines individuellen Touchpanels entsprechend der Tageszeit und Ihrer Vorlieben. Die Lampe verfügt über einen eingebauten Bewegungs- und Tageslichtsensor. Die Lampe ist mit einem Verbindungskabel mit Sicherheitsstecker ausgestattet. Pulverbeschichtet (weiß, grau oder schwarz). Für den Arbeitsplatz geeignete Lichtverteilung mit hervorragender Blendungsbegrenzung (UGR < 6).

system power	80W
light distribution - up	110°
light distribution - down	50°
color temperature	3000K - 6000K
electrical control	ON/OFF DIMM DALI 1-10V tunable white motion + daylight sensor
housing color	white gray black
mounting type	floor
IP	IP20
CRI	>80
UGR	<6

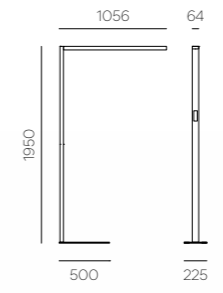

light distribution - up & down

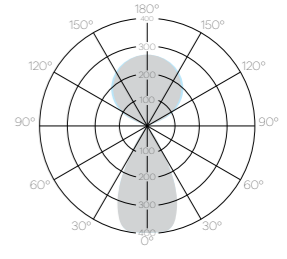

■ C0-C180 ■ C90-C270 cd/1000lm



SHOWROOM HUMAN OFFICE

Movy Eco Floor

EN

Individual floor lamp, specially designed for home office use. The lamp has an on/off switch in the upper part of the luminaire. Light distribution suitable for the workplace with excellent glare reduction (UGR < 19). The lamp has a connection cable and a safety plug. Powder-coated lamp in white, grey or black.

DE

Individuelle Stehlampe, speziell für den Einsatz im Home Office. Schalter im oberen Teil des Lampenschirms. Für den Arbeitsplatz geeignete Lichtverteilung mit hervorragender Blendungsbegrenzung (UGR < 19). Die Lampe ist mit einem Verbindungskabel mit Sicherheitsstecker ausgestattet. Pulverbeschichtet (weiß, grau oder schwarz).

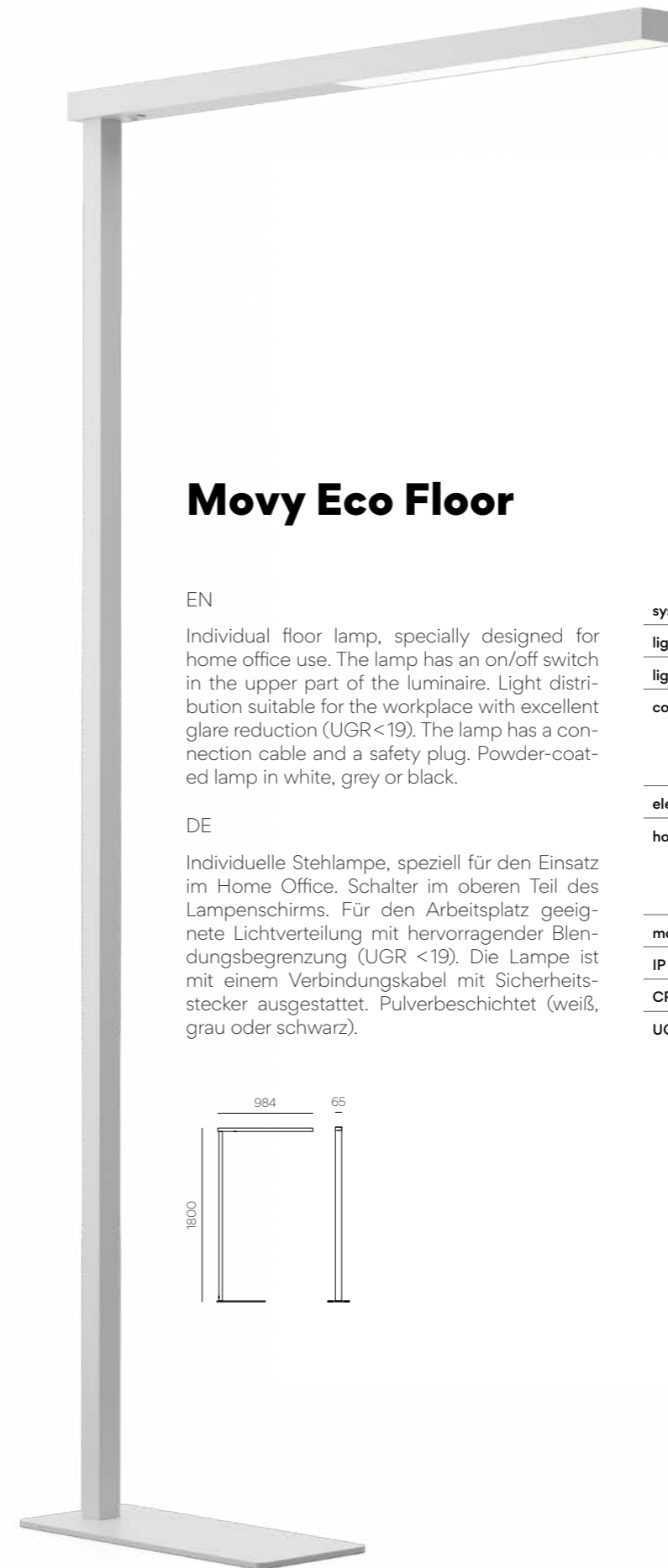
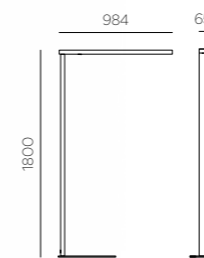

system power	50W
light distribution - up	110°
light distribution - down	90°
color temperature	3000K
	4000K
	6000K
electrical control	ON/OFF
housing color	white
	gray
	black
mounting type	floor
IP	IP20
CRI	> 80
UGR	< 19

light distribution - up & down

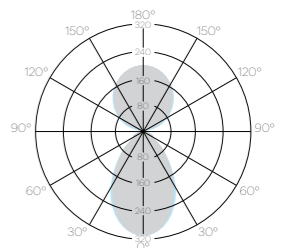

■ C0-C180 ■ C90-C270 cd/1000lm

flexx



SHOWROOM HUMAN OFFICE

Movy Standard Table

EN

Individual tabletop screw-in lamp with micro-reflector and anti-glare cover. Control light intensity and color with the individual touch panel, following the rhythm of the day and your taste. The lamp has a built-in motion and daylight sensor. The lamp has a connection cable and a safety plug. Powder-coated lamp in white, grey or black. Light distribution suitable for the workplace with excellent glare reduction (UGR < 6).

DE

Individuelle Lampe zum Anschrauben an die Tischplatte, mit Mikroreflektor und Blendschutz. Steuerung von Intensität und Farbe des Lichts mithilfe eines Touchpanels entsprechend der Tageszeit und Ihrer Vorlieben. Die Lampe verfügt über einen eingebauten Bewegungs- und Tageslichtsensor. Die Lampe ist mit einem Verbindungskabel mit Sicherheitsstecker ausgestattet. Pulverbeschichtet (weiß, grau oder schwarz). Für den Arbeitsplatz geeignete Lichtverteilung mit hervorragender Blendungsbegrenzung (UGR < 6).

system power	80W
light distribution - up	110°
light distribution - down	50°
color temperature	3000K - 6000K
electrical control	1-10V tunable white motion + daylight sensor
housing color	white
	gray
	black
mounting type	table
IP	IP20
CRI	>80
UGR	<6

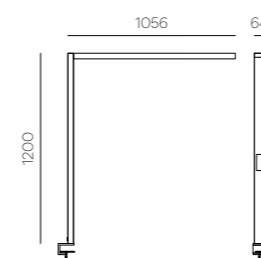

light distribution - up & down

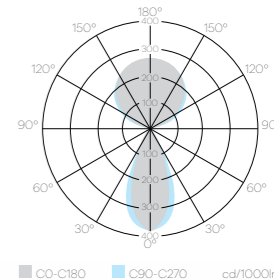

This is not the end!

Now, let's do the project
#together!

Send us an email at:
hello@flexx.design

**Find
Your
color!**

Color PRISM fabrics by BWF Feltec

EN

The BWF Feltec felt color palette is 40 colors of 5mm-thick felt. Wool felt made in Germany has many technical uses, including, among others, in acoustics. The natural properties of wool make this felt not only look designer but also absorb noise and sound perfectly.

DE

Die Farbpalette von BWF Feltec umfasst 40 Filzfarben mit einer Dicke von 5 mm. In Deutschland hergestellte Wollfilze haben viele technische Anwendungen, u. a. in der Akustik. Die natürlichen Eigenschaften der Wolle verleihen diesem Filz nicht nur ein Design-Look, sondern auch eine perfekte Dämpfung von Lärm und Geräuschen.



*Original product colors may vary from those illustrated.

M&K Filze

EN

The M&K Filze color sheet contains a palette of colors of the 5 mm-thick felt design fabric. This fabric is manufactured 100% of merino sheep wool, which guarantees a high level of noise absorption.

Choose from over sixty colors and three collections: Natur, Melange, and Uni, and give our luminaires an individual character. Match it perfectly to your project!

DE

Die Farbpalette von M&K Filze enthält Farbtöne für 5 mm starke Filz-Design-Stoffe. Dieser Stoff besteht aus 100% Merino-Schafwolle, was eine hohe Schallabsorption garantiert.

Wählen Sie aus über sechzig Farben und drei Kollektionen: Natur, Melange und Uni und verleihen Sie unseren Leuchten einen individuellen Charakter. Passen Sie sie perfekt an die Bedürfnisse Ihres Projekts an!

Natur



Melange



Uni



*Original product colors may vary from those illustrated.



Flexx PET, polySONIC® by BWF Group and Nitona® – PET solutions

EN

A color palette of PET sound panels with a thickness of 5 mm, 7 mm, 9 mm, 10 mm, 12 mm, 14 mm to choose from. The high-quality PET sound panels are robust, durable, and have a slightly textile surface that can be washed. They have excellent sound-absorbing properties, are flame-resistant and recyclable.

DE

Farbpalette von PET-Akustikplatten mit einer Dicke von 5 mm, 7 mm, 10 mm, 12 mm, 14 mm zur Auswahl. Hochwertige PET-Akustikplatten sind massiv, strapazierfähig, mit einer leicht textilen Oberfläche, die gewaschen werden kann. Sie haben hervorragende Schalldämmeigenschaften, sind schwer entflammbar und können recycelt werden.

polySONIC® colors 5, 7, 10, 14 mm

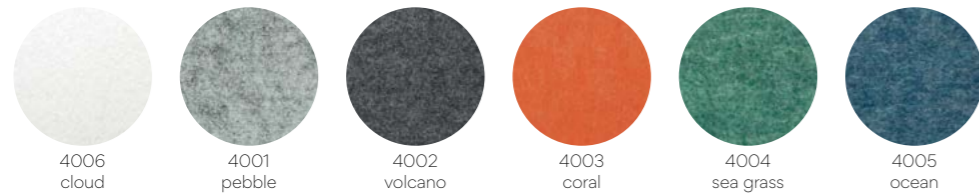

NITONA® colors 10 mm

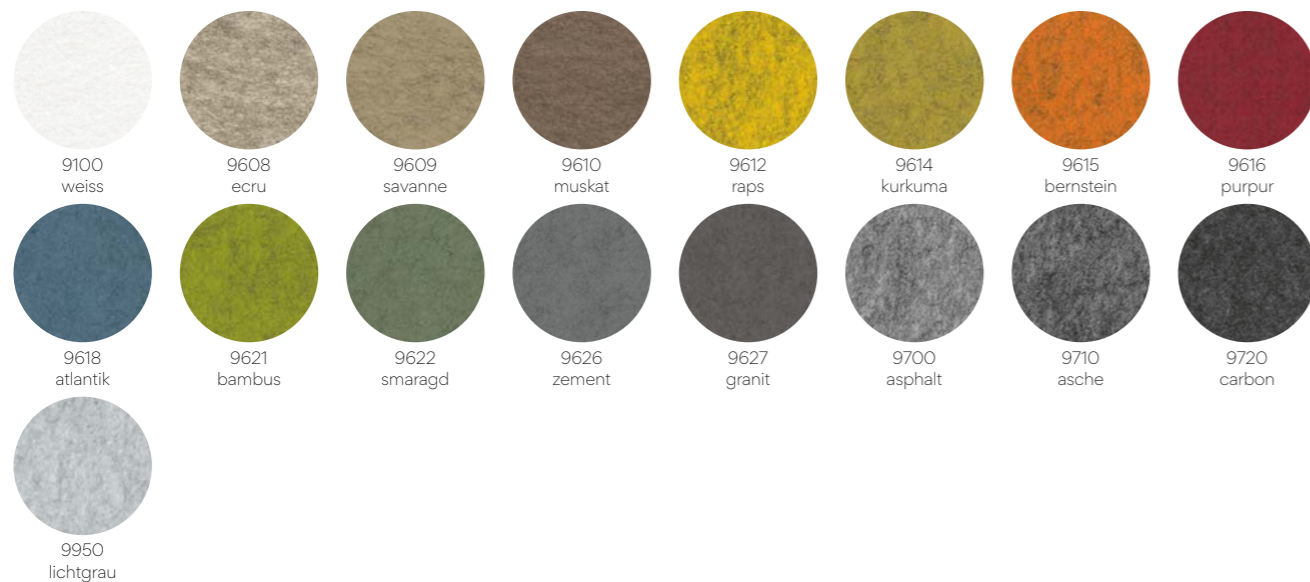

Flexx PET colors 12 mm

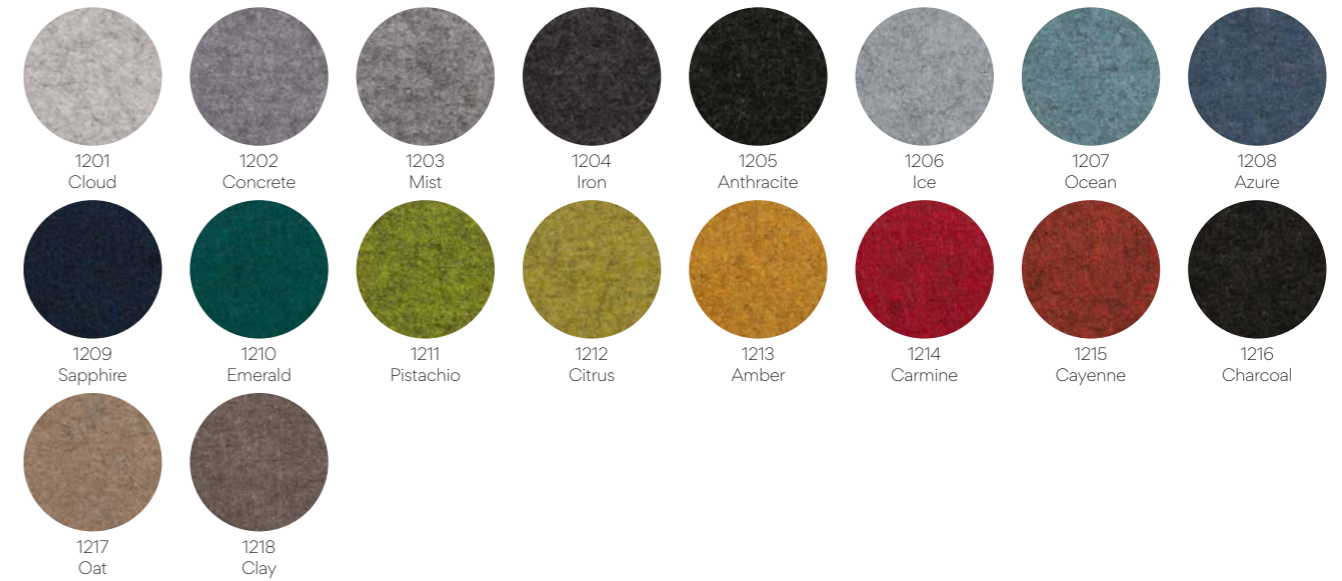

Flexx PET colors 9 mm

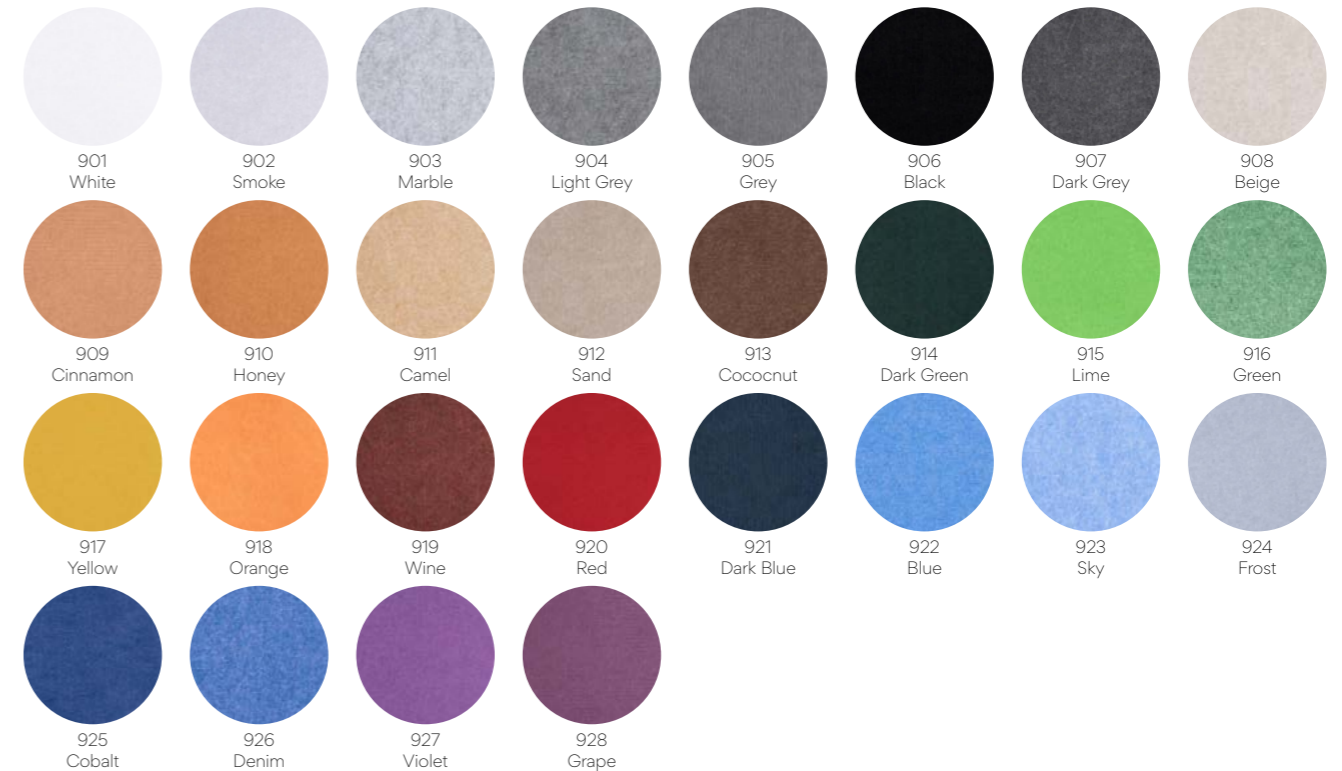

*Original product colors may vary from those illustrated.

Synergy fabrics by Camira

EN

The Camira fabrics color range features 75 shades of Synergy woolen fabric.

The fabric is made of the highest quality New Zealand wool and blended only with 5% polyamide.

It is very soft, strong, has an impressive wear resistance, and in combination with other materials used in our luminaires, has excellent acoustic characteristics.

DE

Die Farbpalette von Camira fabrics umfasst 75 Farbtöne des Synergy-Wollstoffs.

Der Stoff ist aus hochwertigster neuseeländischer Wolle gefertigt und mit nur 5% Polyamid verbunden.

Es ist sehr weich, stark, hat eine beeindruckende Abriebfestigkeit und hat in Kombination mit anderen Materialien, die in unseren Leuchten verwendet werden, hervorragende akustische Eigenschaften.



* Original product colors may vary from those illustrated.

A word of thanks to all of our partners who helped with the support and realisation of this catalogue. In particular with regards to the companies and architects who provided their project photos.

All details provided in the catalogue comply with available data at the time of publication, and are for information purpose only. Flexx.design has the right to change/modify technical data any time without prior information. Flexx.design is not liable for color variation. Some of the pictures are retouched and are just to show installation possibilities. See Flexx.design business conditions and delivery terms on flexx.design.

PHOTOGRAPHY

Carpet Studio
s. 56

Dreamstime
s. 40, 62

Ernest Wińczyk
s. <NT>, <NT>, <NT>, <NT>, <NT>, <NT>, <NT>, <NT>, <NT>, <NT>, <NT>, <NT>, <NT>, <NT>, <NT>, <NT>

Fotomohito
s. <NT>, <NT>, <NT>, <NT>, <NT>, <NT>, 32, 42, 46, 50, 54, 58, <NT>, 100, 113, 130, 132, 134, 138, 140, 148, 150, 152, 154, <NT>, <NT>

Istock
s. 34, 44, 48, 60

Patryk Lewiński, Adgar Poland / The Brain Embassy
s. 106

PION Studio
s. 36, 52, 120

Szymon Polański
s. 38

See you soon!

